

# solo<sup>®</sup>

## 546 / 546R / 546HR / 546RS

*Instruction manual*  
*Original instructions*

*Lawn Mowers*

***Important!***

Read this instruction manual carefully before first operation and strictly observe the safety regulations!



# Instruction manual

Original instructions

## **GB** Preface

Dear Customer,

Congratulations for choosing this SOLO quality product.

The lawn mower is a high performance mower that will contribute to a well-cared for lawn.

 The owners manual comes with the appropriate engine owners manual which is an integral part of this owners manual.

Please read the owners manual carefully and familiarize yourself with the correct use of the SOLO lawn mower prior to operating the lawn mower for the first time. Please observe all instructions, recommendations and explanations. Adherence to the owners manual is essential for proper operation of the lawn mower. Do not operate the lawn mower while other persons, especially children or animals are within close proximity. The operator of the lawn mower is responsible for any personal or property damages to third parties.

**EC declaration of conformity** → The EC declaration of conformity on a separate piece of paper forms part of these operating instructions.

### Packaging and disposal

Please keep the original packaging in order to protect the equipment against transport damage in case you ever need to ship it or transport it. If the packaging materials are no longer required then they must be disposed of properly in accordance with applicable local regulations. Cardboard packaging materials are raw materials which can be recycled or reused.

At the end of the equipment's service life, please make sure that you dispose of it properly, in accordance with the official directives and regulations that apply in your area

## **Symbols**

The following symbols are used in this manual and on the product:



Always handle this power tool with particular care



Read these operating instructions and those appertaining the motor, carefully, before initial start-up and all maintenance or cleaning work



Wear protective gloves when servicing and for repair



Wear protective head gear



Pay particular attention when handling fuel



Never smoke near the power tool or where the equipment is refuelled!



Keep open flames away from the power tool and the fuel can



Observe mowing hours



Do not allow third parties within the danger zone

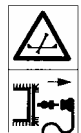

Detach spark plug wire prior to working on cutting device;



Stop engine



Do not spray the mower with high pressure cleaning hose



Never place the lawnmower on its side

In the best interest of continued technological progress we reserve the right to change the design and configuration of any product without prior notice.

For that reason, no claims can be accepted with reference to text and illustrations in this manual

## Index

	Page
<b>1. Type plate</b> .....	<b>3</b>
<b>2. Standard delivery</b> .....	<b>4</b>
<b>3. Control and function elements</b> .....	<b>4</b>
<b>4. Technical data</b> .....	<b>6</b>
<b>5. Accessoires</b> .....	<b>6</b>
<b>6. Safty guidelines</b> .....	<b>7</b>
6.1 Correct use	7
6.2 General safety instructions	7
6.3 Fuel and fuelling	7
6.4 Prior to Mowing	8
6.5 During Start-up	8
6.6 Handling	8
6.7 Information for lawn mower with electrical starter (546RS)	9
6.8 Service and Storage	9
<b>7. Preparing the equipment for use</b> .....	<b>10</b>
7.1 Engine	10
7.2 Assembly	10
7.3 Grass Catching Device	10
7.4 Adjusting cutting height	10
<b>8. Starting / Stopping the engine</b> .....	<b>11</b>
8.1 Starting	11
8.2 Self-propelled drive roller (546R / 546HR / 546RS)	11
8.3 Shutting off engine	11
<b>9. Mowing hints</b> .....	<b>12</b>
9.1 Mowing with Grass catching device	12
9.2 Lawn Care	12
<b>10. Maintenance and Care</b> .....	<b>13</b>
10.1 Cleaning the Mower	13
10.2 Wheel axles and wheel hubs	13
10.3 Height adjustment	14
10.4 Drive belt	14
10.5 Oil level check	14
10.6 Mowing Blade	15
10.7 Air filter Maintenance	15
10.8 Possible faults and troubleshooting	16
<b>Guarantee</b> .....	<b>17</b>
<b>Parts subject to wear and tear</b> .....	<b>17</b>

## 1. Type plate

- a: Type designation  
b: Serial number  
c: Build year (07 → 2007)  
d: Max. speed (operating)



## 2. Standard delivery

- Lawn mower
- Grass catching device complete with frame and carrying handle
- Charger, Ignition keys (only with 546RS)
- Spark plug wrench
- Owners manual, owners manual for engine
- EC declaration of conformity on a separate piece of paper

## 3. Control and function elements

Fig. 1a

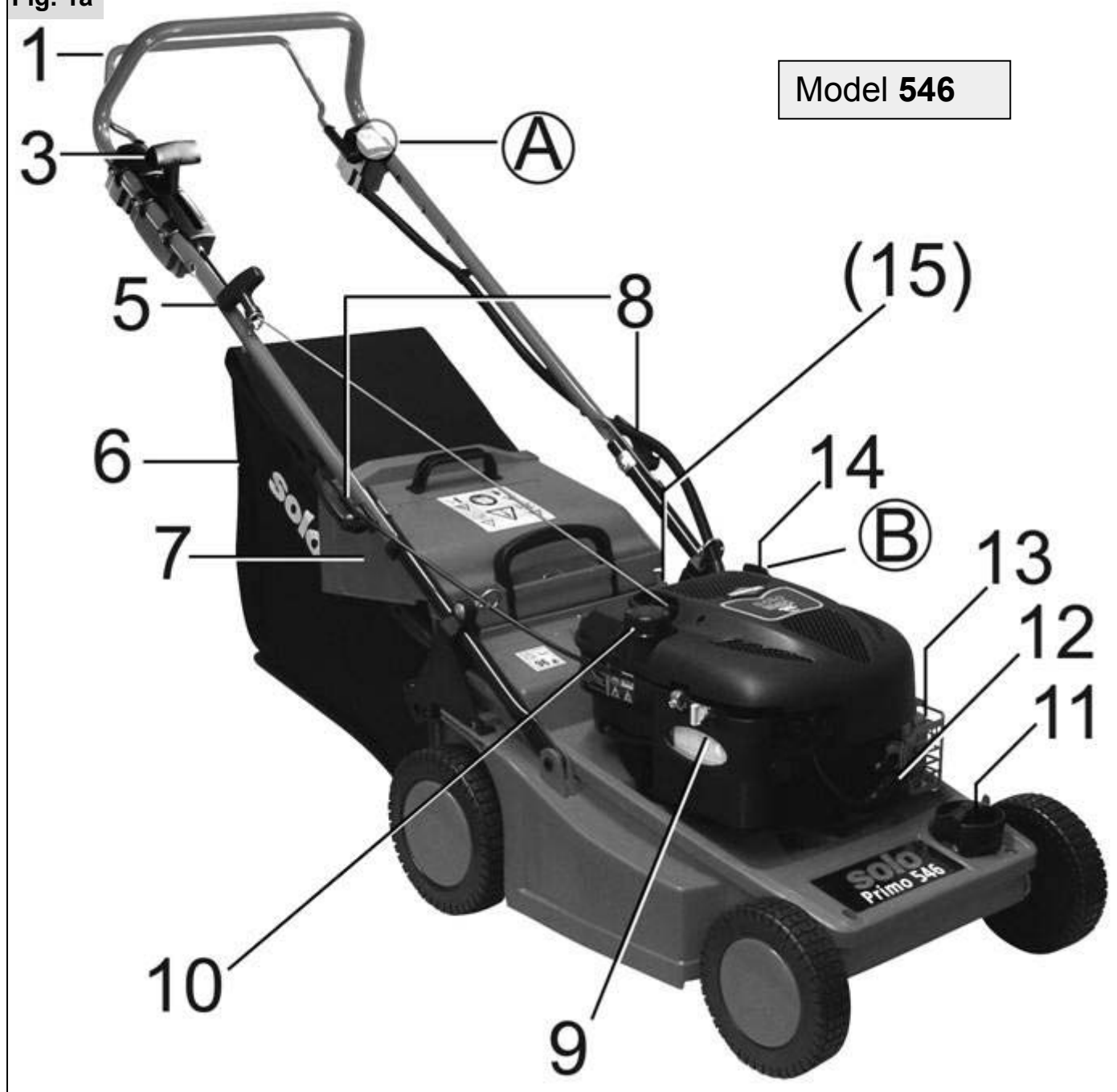

### Adhesive labels:

Ⓐ Model 546:



To stop the engine → release bow handle (1)

Model 546R, 546HR, 546RS:



To start the self-drive → pull bow handle (2) against the tubular handle  
To stop the engine → release bow handle (1)

Ⓑ Fill the engine with oil before taking the machine into use

Controls that are subject to model:

Fig. 2a: **546R, 546HR**

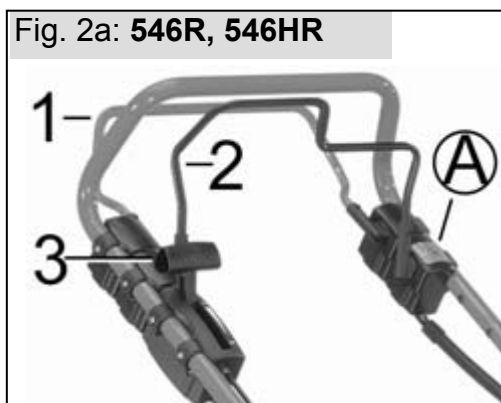
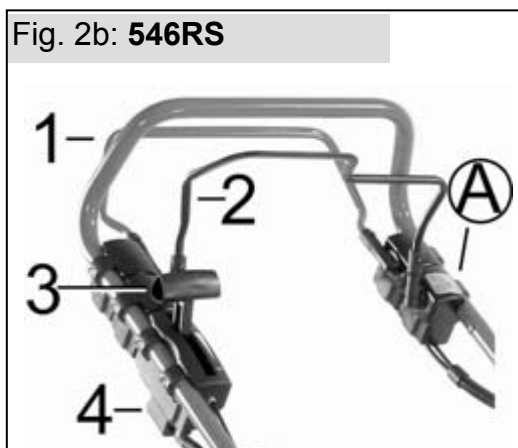

Fig. 2b: **546RS**



Engines that are subject to model

models **546R** and **546RS** as per model **546** (Fig.1)

Fig. 2d: Engine **546HR**

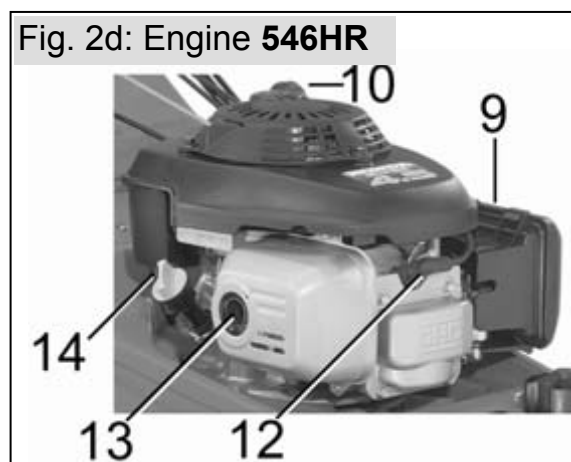

1. Brake lever, engine brake	9. Air filter
2. Drive lever, self-propelled ( <b>546R, 546HR, 546RS</b> )	10. Fuel tank
3. Throttle lever	11. Central height adjustment
4. Key for electrical start-up ( <b>546RS</b> )	12. Spark plug
5. Starter grip	13. Muffler
6. Grascatching device	14. Oil filler pipe
7. Ejection shield	15. - Battery ( <b>546RS</b> ) and
8. Pinning lever	- Gear box ( <b>546R, 546HR, 546RS</b> )

#### 4. Technical data

Mower	546	546R	546RS	546HR
Cutting width cm	46			
Wheel adjustment	continuous central adjustment from 30 - 75 mm (approx. 1" - 3")			
Grass catching device Vol. l	50			
Blade	Blower-blade, one piece, mounted to overload clutch			
Total weight with grass catching device kg	30	33	36	32
1-cyl., 4-cycle engine	Briggs&Stratton Series 650 READYSTART™ 2,4 / 2800		Briggs&Stratton Series 650 E-START 2,4 / 2800	Honda GCV 135E
Engine power kW at rpm				2,1 / 2800
Engine capacity ccm	190			135
Fuel	Lead-free reg.			
Engine oil: SOLO all-season 4-stroke engine oil 0083115	approx 0.6 l			ca. 0.55 l
SOLO gearbox oil 0083182	---	50 ml		
Noise level in work area $L_{pA}$ (ISO 11094)	→ 85 dB(A)			
Sound capacity level $L_{WA}$ (ISO 11094) measured/ garanted	→ 95 dB(A) / 96 dB(A)			
Weighted acceleration value $a_{vhw}$ (EN 836)	→ 12 m/s <sup>2</sup> ± 0,5 x a			
Measurements: a: 140 cm (~55"), b: 105 cm (~41"), c: 51,5 cm (~20"), d: 92 cm (~36"), e: 40 cm (~16")				

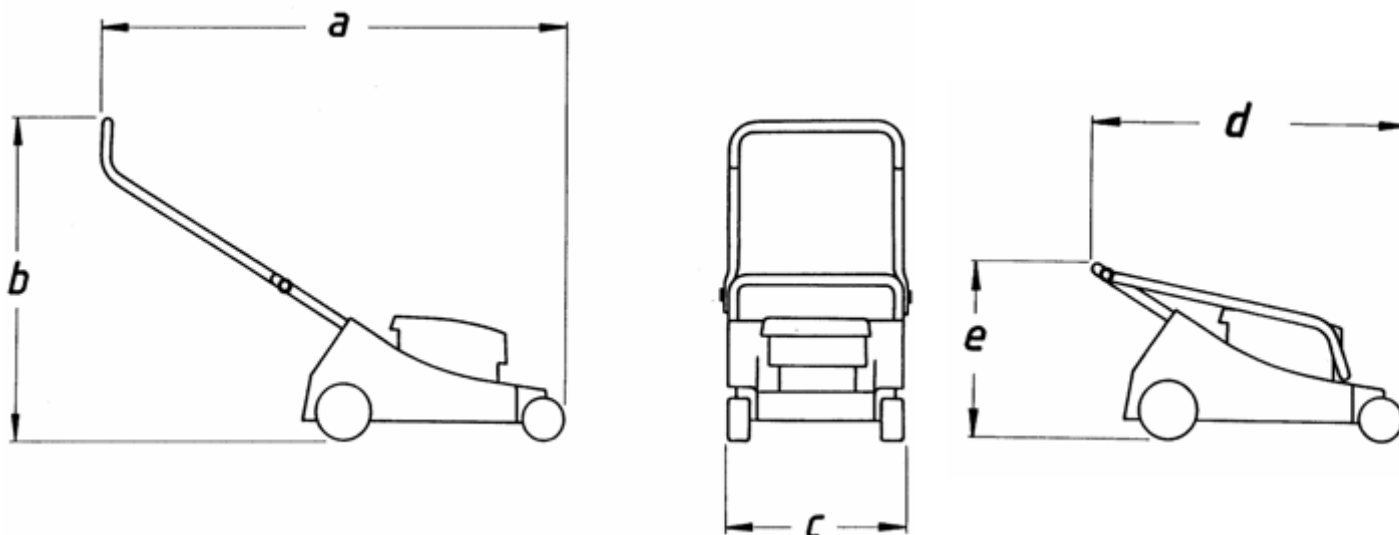

#### 5. Accessoires

	Part no.
<b>Mulch set</b> cutting deck insert and special blade	59 00 830
<b>Deflector</b> set to convert to side discharge mower	59 00 800
SOLO all-season <b>4-stroke engine oil</b>	00 83 115
SOLO <b>gearbox oil (546R, 546HR, 546RS)</b>	00 83 182
SOLO <b>bearing grease</b>	00 83 175
<b>Drive Speed Reduction Kit</b>	59 00 862
<b>Caution:</b> An authorized specialist service centre must install the kit!	

## 6. Safty guidelines

### 6.1 Correct use

The SOLO lawn mower is intended to be used only for private home or hobby gardens. The lawn mower is not to be used in public facilities, parks, sports centers or for agricultural and forestry purposes.



Due to potential bodily harm, the SOLO lawn mower is **not** to be used for the following purposes:

- to trim bushes, hedges or shrubs,
- to cut or chop growing vines or lawns on roof-tops or balcony window boxes,
- to clean or suction-up walkways or to chop up trees and shrubbery debris,
- to cut up tree and shrubbery sections.
- to level elevations on the ground, for instance mole hills or other similar elevations,
- a drive aggregate for other work units,
- as a trailer,
- as a dynamo with a self-propelled drive roller mower (for example for carrying and transporting lawn debris), except with the intended grass catching bag. The warranty becomes invalid if these rules are not observed.

### 6.2 General safety instructions

- Do not allow children or other third parties who are not familiar with the functioning of the machine to operate the lawn mower. Juveniles under age 16 should not be permitted to operate the lawn mower.
- Please adhere to local ordinances which may determine the minimum age for operating the lawn mower.
- Loan the lawn mower only to individuals who are familiar with handling this model. Always make the owners manual available to them.
- Explain to the individual who is to use the lawn mower, how to avoid possible danger and accidents.
- Mow only during daylight hours or with proper artificial illumination.
- Individuals who have a pacemaker should stay clear off the electrical wires of the starter when engine is started or when engine is running.
- Mowers with BRIGGS+STRATTON -4-cycle engines are not suitable for inclines over 15 degrees.
- Lawnmowers equipped **with HONDA OHC Engines can be used on slopes with an incline of max.20 degrees.**
- Store the mower in a safe manner! Mowers should be stored in a dry and locked area that is inaccessible to children.

### 6.3 Fuel and fuelling



Handling gasoline requires great care.

- Gasoline is highly flammable. Refuel only outdoors - never in enclosed areas.
- Smoking and open fires are prohibited.
- Do not spill any gasoline.
- If gasoline is spilled, clean lawn mower immediately, otherwise do not start engine!
- Avoid contact with gasoline. Change clothing if accidental spills occur!
- Be careful that fuel does not spill onto the ground (environmental protection!)
- Transport and store gasoline only in authorized and marked containers.
- If damages occur, replace fuel tank, cap and fuel lines
- Check for any visible damage.

Lead-free, regular gasoline is to be used.

- Refuel only with the recommended fuels which are listed in the separate engine owners manuals.
- Let mower cool off prior to refueling.
- Thoroughly clean the surrounding areas of the fuel tank. Remove fuel tank cap and fill tank to the lower edge of the filler pipe. Firmly close fuel tank cap.



Gasoline may contain solvent-like substances.

- Avoid hand and eye contact with gasoline.
- Wear protective gloves when refueling.
- Do not inhale gasoline fumes.
- Store fuel in areas inaccessible to children.

## 6.4 Prior to Mowing

- Check the area completely prior to mowing and during mowing. Remove any foreign matter such as pebbles, stones, wooden pieces, bones, etc. prior to mowing.
- Never mow without sturdy shoes and without wearing long pants. Never mow bare-footed or with open-toe sandals.
- Attach the ejection shield and the grass catching device. Make certain that these are properly secured. It is prohibited to use the mower without the ejection shield or with a damaged shield.
- Check the mower for
  - a) secure fit of fastening parts,
  - b) damage or severe wear and tear.
- Observe installation hints and specified torque when replacing parts.
- Check the grass catching device frequently for wear and tear.
- Lawn mowers with 4-cycle engine need to be serviced with engine oil prior to first-time usage (observe the hints in the separate engine owners manual).
- Check the oil level prior to each mowing.

## 6.5 During Start-up

- The drive has to be disengaged when starting a self-propelled drive roller mower.
- The mower needs to be positioned on level ground when starting.
- Do not start-up in deep grass.
- When starting mower it is important that feet are away from the cutting unit.
- Never place hands or feet near moving parts. Be careful that neither hands nor feet will be caught below the deck.

## 6.6 Handling

 Do not run the engine in enclosed areas where dangerous exhaust fumes may collect. Danger of poisoning!

- The engine/exhaust becomes very hot: Do not touch!
- Always position yourself firmly on the ground when mowing on a slope.
- Move at a walking pace when mowing.
- Mow diagonally on a slope, never in a straight upward or downward motion.
- Be especially careful when changing directions on a slope.
- Be especially careful when turning mower around or when pulling mower towards you.
- Do not walk backwards with the mower. Danger of stumbling. Avoid walking backwards.
- Avoid abnormal body positions. Assure solid positioning on the ground, and at all times, keep your balance.
- Always keep sufficient distance which is established by the length of the handle.



### Turn off engine and remove spark plug cap.

- Prior to checking the mower,
- prior to removing blockages of ejected material,
- or prior to cleaning the mower and for other maintenance work, and
- when you mount the Assembly mulching Set
- when the mower is temporarily left alone,
- when the mower is lifted or tilted during transport.

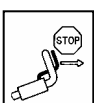

### Turn engine off when.

- Opening the ejection shield and when removing grass catching device,
- when removing the upper handle section from the lower handle section,
- when pushing mower outside the lawn,
- when the cutting height is to be adjusted,
- prior to refueling.
- when crossing areas other than grass
- when transporting the mower to or from the grass area



- Never lift or carry the mower when engine is running.
- Never use the mower when ejection shield is damaged or missing. Mow only with the proper grass catching device which has to be correctly installed, and with a completely closed ejection shield.
- Do not alter the engine's initial settings.
- If the mower becomes blocked, for example when running over an obstacle, the mower needs to be checked by a specialist to see if parts are damaged or deformed.
- Immediate checking is required if the mower vibrates at an unusual high level.

### 6.7 Information for lawn mower with electrical starter (546RS)

- Note the battery-manufacturer's information which is included with each new machine.  
**Attention:** To protect against battery discharging during shipping, the plug on the red cable of the battery connection is equipped with a protective hose. This hose is to be removed prior to connecting the battery.
- Charge the battery 24 hours prior to operating the mower. It is possible that the batteries have become discharged due to extended storage.
- Never charge the battery with a charger intended for other purposes (such as a charger for an automobile) since the battery may become damaged.
- The battery is located under the lid next to the ejection passageway of the lawn mower deck. Make certain that the charger is connected to the battery and not to the engine's main cable; otherwise the charger may become damaged.
- Frequent starting and stopping may lead to a discharged battery (complete discharging is damaging to the battery). In this situation it is necessary to quickly charge the battery with the charger.
- Never store a discharged battery since the battery may become permanently damaged.
- Disconnect the battery from the main cable of the mower if the mower is not used for more than 14 days.
- Prior to storing the mower at the end of a season, charge the battery for 24 hours with the supplied charger. Do not reconnect the battery, store in a cool and dry place (never above 23°C (73° F)). The battery needs to be recharged within 6 months of the last charge.
- Recharge the battery for 24 hours with the supplied charger prior to operating the mower in the Spring.
- The battery is completely enclosed and does not require any additional servicing.
- Defective batteries need to be disposed off properly in accordance with local regulations. Some local shops may accept and dispose off defective batteries.

### 6.8 Service and Storage

**Caution:** Before every Service, Cleaning and Storage stop the engine and remove spark plug cap.

- Take care that all screw connections are tightened.
- Never store the mower with gasoline in fuel tank in a building where gasoline vapors may come in contact with open fires or where sparks could ignite fumes.
- The fuel tank should be emptied outdoors. Use suitable containers for draining gasoline.
- Let the engine run until the gasoline remaining in the carburetor is depleted.
- Let the engine cool off prior to storage in an enclosed area.
- To avoid danger of fire, clean grass, leaves or escaping grease (oil) off engine, muffler and fuel tank.
- On a regular basis, check the grass catching device and check the ejection shield for wear and tear and sound operation.
- For safety reasons, replace worn or damaged parts.
- Always wear protective gloves when working near the cutting device's vicinity.
- Servicing and repairs are only to be conducted when engine is turned off and when spark plug cap is removed.
- For warranty purposes and safety reasons only SOLO replacement parts should be used.

Ensure that the tank is fully drained before any assembly, disassembly or modification.

## 7. Preparing the equipment for use

### 7.1 Engine

Prior to start up, carefully read the engine operating manual and the following instructions. Adhere to all instructions to assure the engine's long life and to keep the warranty valid.

### 7.2 Assembly

Your lawnmower will be ready for use in only a few steps.

#### Securing the handle:

- Open locking screws (8)
- Pivot the upper handle into the required position – if required, release locking screws (8) a little.
- Turn the open locking screw far enough inwards to ensure that both handle parts sit closely together when the locking levers are closed. If required, either tighten or relax the locking screws by one full turn.

**Tip:** Lock the locking screw levers upwards to ensure that, whilst mowing, the screws do not catch on shrubs.

Secure the Bowden and other cables in the cable guides.

#### Folding the handle again for transport or storage:

When folding the handle, open both locking screws upwards and tilt the upper handle forward. Note: On **lawnmowers with self-drive**, push the control bar (2) against the handle, before folding the handle over, to prevent damaging the spark plug

#### Starter handle inserted in the cable guide

Release the engine brake by bushing brake lever, A (1), to the handle. Put the starter grip (5) in the cable guide which is located on the upper handle part.

**Attention:** When folding and unfolding the handle, pay special attention that the Bowden cables are not bent and run smoothly..

**Caution!** Assure that Bowden cables are not caught up anywhere and that they have not become damaged during transport!

### 7.3 Grass Catching Device

**Caution!** Assemble and disassemble grass catching device only when engine is shut off!

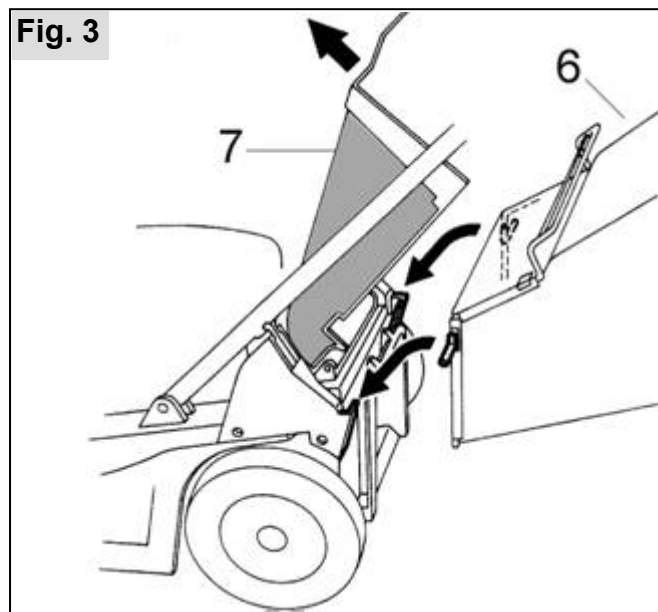

To install grass catching device, lift ejection shield (7), with one hand. With the other hand, hold grass catching device (6), at the carrying grip and link into mower deck at an angle from above.

### 7.4 Adjusting cutting height



The mower is equipped with a continuously adjustable cutting height of approx. 30 - 75 mm (approx. 1 - 3 inches). The height adjustment for all wheels is accomplished by the central adjustment (position 11). Turning to the right reduces the cutting height, and turning to the left increases the height. The height can be read from the markings.

**Attention:** The cutting height is to be set so that the blade does not touch the ground when the ground is not level. Only mow with the lowest cutting adjustment when lawns are flat.

## 8. Starting / Stopping the engine

During start up with self-propelled drive roller mower, the drive has to be disengaged. When starting the mower, position yourself on the side or behind the mower. The safety distance which is given by the handle is always to be adhered to.

**Caution!** The cutter operates as soon as the engine starts! Never reach with your hands under the deck and never slide a foot under the deck!

### 8.1 Starting

#### Model 546HR



#### Cold start:

Move throttle control (3) to the choke symbol  $\Sigma$ . After the engine starts, put throttle lever (3) on position "max".

#### Starting a warm engine:

Move throttle control (3) to "max".

#### Model 546, 546R, 546RS

The choke position is automatically adjusted through a bimetal sensor subject to engine temperature (Ready-Start®). These models require no manual adjustment for a cold start.

#### Starting:

**Attention:** To release the engine brake when starting the engine, the brake bar (1), needs to be pushed towards the handle.

If the brake bar (1) is not pushed to the handle during start, the electrical ignition is shorted and the engine brake is activated. In this situation, the engine cannot be started with manual start up and electric start.

#### Model 546, 546R, 546HR:

Pull out starter rope until resistance is felt - then pull rapidly and with force.

#### Electrical Starter (546RS):

Put the ignition key in the ignition (4) on the throttle lever and turn 1/4 clock-wise.

### 8.2 Self-propelled drive roller (546R / 546HR / 546RS)

On lawn mowers with self-propelled drive, the drive lever is located in front of the guide bar. The self-propelled drive can only be put into gear after the engine starts. To engage the drive, the drive lever (2), has to be pulled towards the grip bar. To stop the drive, release drive lever. In its released state, there is no drive and the lawn mower can be pushed forward or backward.

### 8.3 Shutting off engine

- Move the throttle lever (3) to "min"
- release brake lever (1) and wait until engine shuts off.

**Note:** When the brake lever is released (1), the electrical ignition of the engine is cut off. The engine RPM and the blade will stop within several seconds

## 9. Mowing hints



When mowing, please observe the safety recommendations which are part of this owners manual!



**Important Note:** The time and duration when lawn mowers can be operated may be subject to local ordinances. These ordinances usually vary from location to location.



Noise is damaging. During extended mowing, we recommend wearing protective head gear to avoid possible hearing loss.

Before mowing, search the lawn and carefully remove any debris (stones, shards, metal objects, twigs, etc.). Leaves, cuttings, etc. do not need to be removed prior to mowing, but can be picked up with the grass catcher.

Note: If, on account of the growth pattern, the full engine power is not required, you can select the Eco position ("Öko") between max. and min. on the throttle control (Fig. 5) to protect the environment.

### 9.1 Mowing with Grass catching device

Short and dry grass can be easily blown in the grass catching device (6). This is made possible by blower-supported grass ejection (turbo effect).

Fig. 6

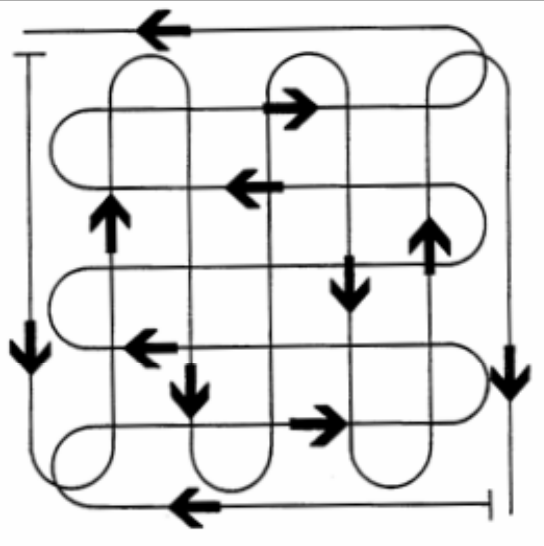

The shorter the cuttings, the better the grass catcher handles them;  
 - excessively long or wet grass could possibly clog-up the catcher or slow down the pick-up.  
 In case of long grass, therefore, first cut with a higher setting in one direction (with generous overlap) and then across the first pattern with a lower or the standard cutting height (Fig. 6).

Grass height, density and grass dampness determine cutting results. Grass that is dry and not too long assures best cutting results. Wet grass may be cut and collected; however, the cutting results and the collection outcome are affected. A sharp blade is essential for best cutting results. A dull blade (grass stems become ragged during cutting and the lawn turns yellow) has to be resharpened (see chapter „Blade“).

### 9.2 Lawn Care

If possible, mow only when the lawn is dry and when the ground is dry. The lawn mower's wheels press into the wet ground and leave compression marks.

A lawn looks better and appears more uniform if cut often. Frequent cutting allows the lawn to become healthy since the growth goes into the stem.

Short cuttings up to 1 cm (approx. 1/2 inch) may be left on the ground, longer cuttings need to be collected with the grass catching device. At Spring time, the first mowing should take place approx. 2 to 3 weeks before the grass grows at its usual level. In order to achieve early greening of the lawn, cut only approx. 1.5 cm (3/4 inch) of the grass. Check lawn for foreign objects (rocks, glass, metal pieces etc.) prior to mowing lawn. The grass catching device can be used for any additional clean-up (leaves etc.).

Newly seeded or thin lawns must not be cut too short (leave 3 - 4 cm) (1 - 1 1/2 inches). Let the grass remain at that length for 4 to 5 weeks, so that the lawn increases in width and density.

**Attention:** SOLO Lawn mowers with rear eject are especially suited for the collection of leaves. However, this use is **only permitted on lawns where all foreign objects, such as stones, shards, metal objects, twigs, etc. have first been carefully removed.** Leaf collection on solid ground (for example, roads or walk-ways) is prohibited due to inherent safety risks.

For leaf collection, the cutting height is to be set to the middle or to the highest setting.

## 10. Maintenance and Care

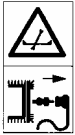

For your own safety, remove the spark plug cap from the spark plug prior to any maintenance work or cleaning (12).

Any maintenance and care that go beyond the described explanations need to be left to an authorized Service Center.

### 10.1 Cleaning the Mower

After each use, the mower needs to be thoroughly cleaned. Special attention needs to be given to the lower side, the blade and the cutting area circle.

**Tip:** To enable the lawnmower to be maintained and cleaned with an empty fuel tank, fill only enough fuel for the mowing job in hand. That way, the tank can be quickly emptied after mowing has been completed.

Fig. 7

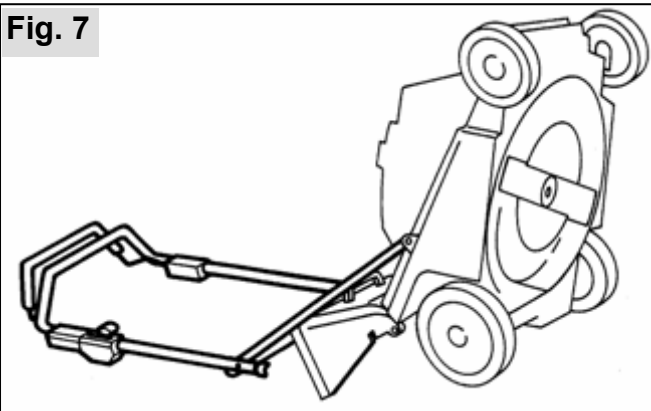

After releasing locking screws (8), the mower can be raised onto its rear wheels and be supported on the lower handle. First pull the spark plug cap. The fuel tank should be empty, if possible, to prevent fuel spilling from the fuel tank cap. Catch any fuel running out of the carburettor with a suitable rag. Dirt and grass debris is removed easily immediately after mowing. Imbedded grass debris and dirt on the mower deck's lower section interrupt the grass collection and affect cutting results. Imbedded dirt on the blade and on the blower wheel lead to imbalance and consequently to vibration. Check also for cleanliness of the duct. The ejection air duct can be cleaned with a small stick or with a screw driver.

**Do not spray the mower with a hose or high pressure cleaning hose.** The engine has to remain dry. The outer deck parts can simply be kept clean by wiping the unit off with a rag. Strong cleaning agents of any kind are not to be used.

### 10.2 Wheel axles and wheel hubs

Fig. 8

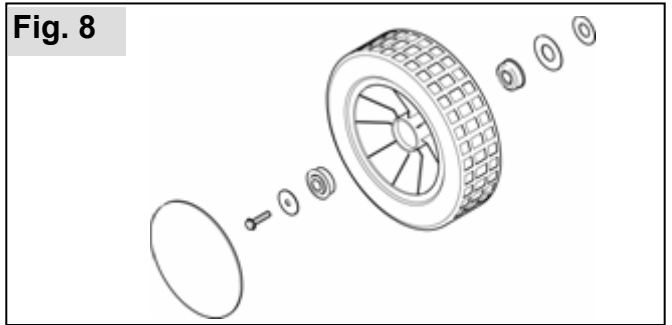

Wheel axles and wheel hubs are to be lubricated occasionally (at least once a year). Remove wheel cap, release screw and remove wheel. During disassembly observe the sequence for the reassembly of the parts. We recommend SOLO bearing grease, part no. 00 83 175.

Maintenance of the rear wheel-self-propelled drive roller:

Fig. 9

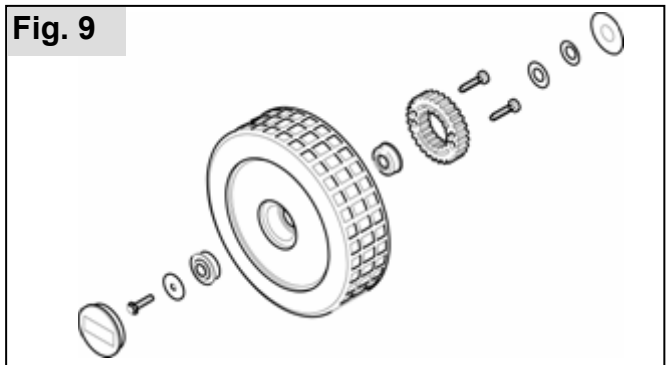

- After removing wheel caps and loosening fastening screws, remove drive wheels.
- Remove grass debris and dirt from all drive wheel areas.

**Attention:** Do not remove neutral gear pinions from the gear shaft; however, check if they turn slightly counter-clockwise to the drive direction.

- Lightly lubricate the two pinions (free wheel and plastic pinion) with water-repellent grease which is compatible with plastic, e.g. SOLO bearing lubricant, part no. 00 83 175.
- Fill the space inside the drive wheel between both taper bearings with the same or a compatible grease.
- Also lubricate the wheel axles with grease.
- When refitting the drive wheel, ensure that both pinions engage with each other; slightly turn the wheel on its axle, if required.

### 10.3 Height adjustment

Before storing your lawnmower out of season clean and lubricate the wheel adjuster spindle with grease (this procedure is necessary at least annually).

For this, set the wheel adjuster to its highest **position (max)**

- clean and lubricate the exposed part of the spindle with grease

- then set the wheel adjuster to its lowest **position (min)**

- clean and lubricate the remaining spindle with grease. For this, we recommend SOLO bearing grease, part no. 00 83 175.

### 10.4 Drive belt

#### Tensioning the drive belt

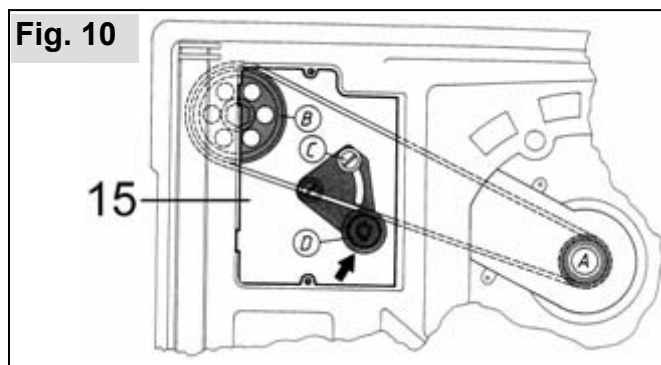

Remove the lid from the battery/gearbox chamber (15) after releasing both screws. Undo the fixing screw (C) of the tensioning lever. Tension the drive belt by moving the tensioning lever (in the direction of the arrow).

**Note:** Check the belt tension every 20 hours or at least once per mowing season.

The belt is correctly tensioned if the centre can be deflected by approx. its own thickness.

#### Changing the drive belt

- Position the lawnmower on its handle and discharge deflector (Fig. 7). First pull the spark plug cap and ensure that the fuel tank is empty.
- First remove the blade and impeller, then the old drive belt.
- Position the new drive belt from below onto belt pulley A and insert to the rear into the mower chassis.
- Reposition the mower on its wheels.
- Position the drive belt onto pulley B on the gearbox side.
- Tighten V-belt as described above.
- Screw on cap tightly.
- Assemble blower wheel and blade. Observe sequence of assembly parts and observe the blade's torque. (Fig. 12).

### 10.5 Oil level check

**Attention:** The engine oil affects the lawn mower's efficiency and life span. Never operate the engine without oil or with little oil. Major engine damage can occur. The optimum viscosity depends on where the lawn mower is used (air temperature and altitude) and can be found in the engine owners manual.

#### Checking Oil level:

Observe the notes and instructions in the type-specific engine operating instructions.

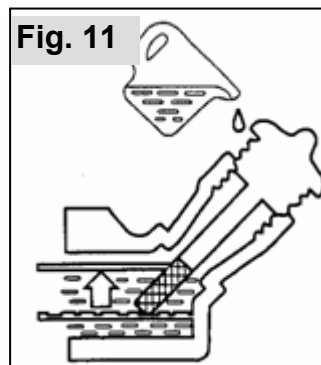

Fig. 11

- Place lawn mower horizontally with all wheels on the ground.
- Turn oil tank cap counter-clockwise (14), and remove. Wipe off dipstick.
- Place dipstick back into filler pipe.

- Remove dipstick, hold horizontally and read oil level. Oil level has to be between the "MAXIMUM" and "MINIMUM" markings.

#### Changing Oil (Briggs&Stratton 4-cycle engine)

The engine oil may be drained via the oil drain screw or the oil filler opening. Blade and blower wheel need to be removed to reach the oil drain screw (illustration 11). Observe especially the service instructions in the separate engine owners manual.

**For the oil change with the HONDA OHC Engine, the used oil is removed by suction which should only be done by a specialist workshop.**

When draining via oil filler opening (14): Tilt the warm mower (with fuel tank empty and closed oil filler) slowly over the side of the filler opening. Remove oil filler cap and catch old oil in a container. Wait several minutes until oil is drained. Dispose of the old oil in accordance with local ordinances.

After changing oil, always wash hands with a scouring agent, soap and water.

**Attention:** Never simply throw away used engine oil and gear lubricant (environmental protection). Collect used oil in authorized containers and submit to the proper recycling facility.

#### Gearbox (546R / 546HR / 546RS)

The gear is equipped with a special permanent oil and operates completely maintenance-free. Technical faults that cannot be resolved by adjusting the Bowden throttle cable are only to be corrected by an authorized Service Center.

## 10.6 Mowing Blade

 Special tools, such as a torque wrench for example, are required to mount the blade to the mower. For safety reasons we recommend that the mowing blade is sharpened, balanced and re-fitted by an authorized specialist workshop only. The following notes are therefore only intended for specialist repair shops.

To obtain best mowing results we recommend to have the blade sharpened / balanced or at least once every year.

### Replacement of Blade

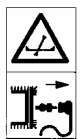

Proper gloves are to be worn when replacing the blade. The spark plug cap has to be removed prior to any work.

Fig. 12

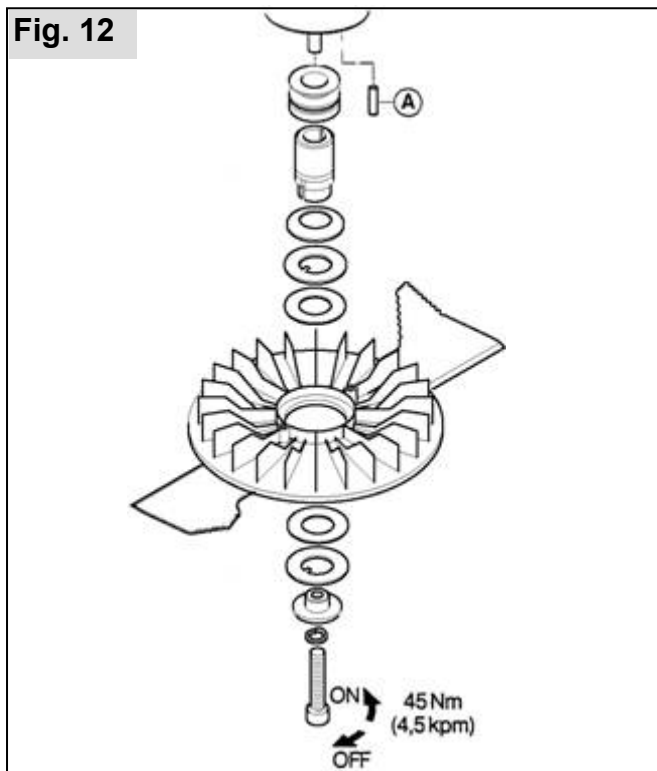

When replacing any blade parts only SOLO spare parts are to be used. The identification No. on the blade has to agree with the Order No. for the replacement. Never install a different type of blade!

Use the holding pin as a blocking device for the blade. The blade fastening screw has a regular right-handed thread. To remove the screw we recommend using a socket wrench 21 mm (spark plug wrench) or hex. wrench 8 mm, 5/16". At re-assembly of the overload clutch be sure and observe the sequence in which these parts were previously assembled. The blade screw is to be tightened with the specified torque of 45Nm (4,5mkp).

### Damaged Blade

The engine needs to be shut off and the spark plug cap has to be removed if the blade has come in contact with a foreign object or other obstacle. After the blade stops, tilt the mower and check the blade for damage. Deformed or bent blades are not to be re-aligned.

Damaged parts are to be replaced immediately. If the mower has been driven over a notable obstacle, the mower needs to be checked by an authorized Service Center. Prior to use make certain that blade and blade fastening parts are not damaged. If necessary, parts need to be checked or replaced. Never operate mower with an unbalanced blade - this would cause vibration and additional damage.

### Sharpening of Blade

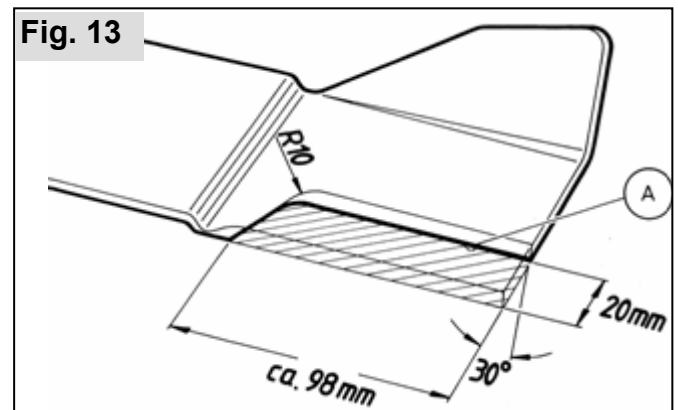

**Attention:** The blade may be sharpened with a metal file; however, we recommend that resharpener/sanding is done by an authorized Service Center who will pay attention that the same amount is sanded off on each side to avoid any imbalance.

The cutting edge of the blade is only to be resanded up to the imprinted markings.

## 10.7 Air filter Maintenance

**Attention:** Dirty air filters reduce the engine's efficiency, the carburetor does not receive sufficient air flow. Routine inspection, especially in dusty conditions, is essential.

**Attention:** Never clean air filter parts with gasoline or flammable solvents. Danger of fire or explosion! Observe all instructions in the respective engine owners manual.

## 10.8 Possible faults and troubleshooting

Problem	Possible Cause	Solution
Mower runs rough, vibrates severely	<ul style="list-style-type: none"> <li>Loose screws on engine or fastening screws loose</li> <li>Blade fastening loose</li> <li>Blade not balanced or damaged</li> <li>Overload clutch worn</li> </ul>	<ul style="list-style-type: none"> <li>Tighten screws</li> <li>Check blade fastening</li> <li>Balance blade or replace</li> <li>If needed, replace disks (in pairs)</li> </ul>
Engine does not start	<ul style="list-style-type: none"> <li>Is brake lever (1) pushed against handle?</li> <li>Is the throttle lever in the correct position? (Model <b>546HR</b>)</li> <li>Is the Bowden cable / the engine brake correctly set?</li> <li>Spark plug or spark plug cap defect</li> <li>Fuel tank empty</li> </ul>	<ul style="list-style-type: none"> <li>Push brake lever</li> <li>Select correct setting</li> <li>Check if setting is correct</li> <li>Clean or replace spark plug</li> <li>Refuel</li> </ul>
Engine runs irregular	<ul style="list-style-type: none"> <li>Air filter dirty</li> <li>Gas Bowden cable bent</li> <li>Spark plug sooty</li> </ul>	<ul style="list-style-type: none"> <li>Clean or replace air filter</li> <li>Adjust Gas B. cable or replace</li> <li>Replace spark plug</li> </ul>
Starter rope backfires	<ul style="list-style-type: none"> <li>Blade fastening or overload clutch loose</li> <li>Blade is dull</li> </ul>	<ul style="list-style-type: none"> <li>Check blade fastening</li> </ul>
Lawn turns yellow, cutting uneven	<ul style="list-style-type: none"> <li>Cutting set too high</li> <li>RPMs too low</li> <li>RPMs too low</li> </ul>	<ul style="list-style-type: none"> <li>Sharpen blade</li> <li>Adjust cutting height</li> <li>Set throttle lever on high</li> </ul>
Mower collects poorly	<ul style="list-style-type: none"> <li>Cutting height set too low when grass is too high</li> <li>Blade worn out</li> <li>Lining of catching device clogged</li> <li>Gear lever not pulled</li> </ul>	<ul style="list-style-type: none"> <li>Set throttle lever on high</li> <li>Adjust cutting height</li> <li>Replace blade</li> <li>Clean or replace catching device</li> </ul>
Self-propelled drive wheel does not run	<ul style="list-style-type: none"> <li>Bowden cable bent or obstructed</li> <li>V-belt tension loose</li> <li>Gear lever not released</li> </ul>	<ul style="list-style-type: none"> <li>Pull gear lever to handle</li> <li>Adjust Bowden cable</li> <li>Adjust V-belt tension</li> </ul>
Drive mower cannot be pulled backwards	<ul style="list-style-type: none"> <li>Bowden cable bent or obstructed</li> <li>Drive wheels dirty inside or not lubricated</li> </ul>	<ul style="list-style-type: none"> <li>Release gear lever</li> <li>Adjust Bowden cable</li> <li>Clean and lubricate wheels</li> </ul>



## Guarantee

The manufacturer guarantees problem free quality and will cover the cost of replacing parts which are found to be faulty in material or show manufacturing defects within the prescribed guarantee period after the date of purchase. Please note that specific guarantee conditions may differ from country to country. When in doubt, please ask the vendor of the goods. The vendor of the product is responsible for guarantee applications.

We hope you will understand that we cannot be liable for damage resulting from these causes:

- Non-compliance with operating instructions.
- Neglecting required maintenance and repair jobs.
- Damage caused by improper carburettor adjustment.
- Wear from normal use.
- Obvious overload by continuously exceeding the upper performance limit of the product.
- Using non-approved tools.
- Use of force, improper treatment, misuse and accidents.
- Damage from excessive heat due to dirt build up around the cooling fan housing.
- Attempted adjustments and repairs by non-qualified persons.
- Use of unsuitable spare parts or non-original parts if such parts are the cause of the damage.
- Use of unsuitable or stale fuel.
- Damage caused by using the product in the hire or rental industry.

Normal cleaning, adjustments or maintenance jobs cannot be claimed as part of the guarantee.

All guarantee work must be carried out by a service centre authorized by the manufacturer.

## Maintenance and repair

Maintenance and repair of modern motorized devices, as well as their safety-relevant assemblies, require qualified, specialized training and a workshop equipped with special tools and test devices.

Thus SOLO recommends that you have a specialized SOLO workshop carry out all work that is not described in these operating instructions. Your SOLO specialist has the required training, experience, and equipment at his disposal to provide you with the most cost-effective solution and can help you in many ways with advice and service.

## Replacement parts

Dependable operation and the safety of your device also depend on the quality of the replacement parts that you use. Use only original SOLO replacement parts.

Only original parts come from the production of the device and thus guarantee the highest possible material quality, dimensional accuracy, function, and safety. Original replacement parts and accessory parts are available from your dealer. He also maintains the requisite replacement part lists to determine the required replacement part numbers, and he is constantly provided with information concerning detail improvements and innovations in the replacement part offering.

Please note as well that guarantee performances from SOLO are not possible if parts other than SOLO original parts are used.

## Parts subject to wear and tear

Various parts are subject to application-specific wear or to normal wear and must be replaced in good time if necessary. The following parts are subject to normal wear and are not covered by the manufacturers guarantee:

- Blade and blade fixing
- Friction pads
- Air filter
- Spark plug
- Fluids, such as engine and gearbox oil
- Drive belts and freewheel 5038437 / 5038438 on lawnmowers with self-drive

In conformance with the product liability law we want to clearly point out that we are not liable for any damages which may occur due to improper handling, or repair. Furthermore, we are not responsible for any damage that may occur if replacement parts other than SOLO replacement parts, or parts that were not authorized by SOLO, have been used. In addition we are not liable for any damage that may occur if repair work was performed by any source other than the Customer Service or an authorized Service Center. This liability exclusion applies also to accessories and supplemental parts.

# **solo**<sup>®</sup>

Made in Germany



SOLO  
Postfach 60 01 52  
D 71050 Sindelfingen  
  
Tel. 07031-301-0  
Fax 07031-301-130  
info@solo-germany.com

SOLO  
P.O.Box 60 01 52  
D 71050 Sindelfingen  
Germany  
Phone+49-7031-301-0  
Fax +49-7031-301-149  
export@solo-germany.com