

## *Instruction manual*

## *Brushcutter*

### ***Important!***

Before using this power tool for the first time, please make sure that you read these operating instructions and the separate operating instructions for the engine carefully and follow all the warnings and safety instructions.



Dear Customer,

Thank you for choosing this quality product from SOLO.

Before using this power tool for the first time, please make sure that you read these operating instructions and the separate operating instructions for the engine carefully and follow all the warnings and safety instructions.

In order to maintain the performance of the brushcutter, it is necessary to carefully follow the service instructions.

Your dealer will be glad to assist you with any questions.

### **Packaging and disposal**

Please keep the original packaging in order to protect the equipment against transport damage in case you ever need to ship it or transport it. If the packaging materials are no longer required then they must be disposed of properly in accordance with applicable local regulations. Cardboard packaging materials are raw materials which can be recycled or reused.

At the end of the equipment's service life, please make sure that you dispose of it properly, in accordance with the official directives and regulations that apply in your area

The following symbols are used in this manual and on the product:



Thoroughly read these operating instructions before undertaking any maintenance, installation and cleaning steps



Wear ear defenders and a face shield before starting the engine



Wear protective gloves when handling and working with the equipment



Wear solid shoes, preferably safety shoes with a good tread



Always handle this power tool with particular care



Maintain a minimum distance of 15 metres bystanders



Please note: objects may be thrown out and high



Please note: power tool may kick back on contact with a solid object

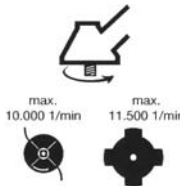

Never exceed the specified maximum speed



Never smoke near the power tool or where the equipment is refuelled!



Keep open flames away from the power tool and the fuel can



- This equipment produces exhaust fumes and  
- fuel vapours are poisonous;  
never start or refuel in enclosed spaces



Never use serrated cutters; generally use only cutters approved for the equipment type

In the best interest of continued technological progress we reserve the right to change the design and configuration of any product without prior notice.

For that reason, no claims can be accepted with reference to text and illustrations in this manual.

	Page
<b>1. Safety regulations .....</b>	<b>4</b>
1.1 <i>Correct use / General safety instructions</i>	4
1.2 <i>Working clothes</i>	4
1.3 <i>Fuelling</i>	5
1.4 <i>When transporting the equipment</i>	5
1.5 <i>Preparing the equipment for starting</i>	5
1.6 <i>Starting</i>	5
1.7 <i>Working with the machine</i>	6
1.8 <i>Maintenance and repairs</i>	6
<b>2. Standard delivery .....</b>	<b>7</b>
<b>3. Control and function elements .....</b>	<b>7</b>
<b>4. Specification .....</b>	<b>8</b>
<b>5. Preparing the equipment for use .....</b>	<b>8</b>
5.1 <i>Loop Handle</i>	8
5.2 <i>Shield installation</i>	9
5.3 <i>Cutter installation</i>	10
5.4 <i>Fitting the flexible shaft to the female connection</i>	12
5.5 <i>Fitting the flexible shaft to the motor flange</i>	12
5.6 <i>Electric and Bowden cable connections</i>	12
<b>6. Fuelling .....</b>	<b>12</b>
6.1 <i>Fuelling</i>	13
<b>7. Starting / Stopping the engine .....</b>	<b>13</b>
7.1 <i>Half throttle start position</i>	13
7.2 <i>Startup settings on the engine</i>	13
7.3 <i>Starting</i>	13
7.4 <i>Turning off the engine:</i>	14
<b>8. Using your brushcutter.....</b>	<b>14</b>
8.1 <i>Scope of Application</i>	14
8.2 <i>Correct brushcutter operation</i>	14
8.3 <i>Note on using the nylon line head (available as accessory)</i>	15
<b>9. Operating and maintenance instructions .....</b>	<b>15</b>
9.1 <i>General operating and maintenance instructions</i>	15
9.2 <i>Lubricating the flexible drive shaft</i>	15
9.3 <i>Gearbox lubrication</i>	16
9.4 <i>Engine components</i>	16
9.5 <i>Shutdown and storage</i>	16
9.6 <i>Scheduled maintenance</i>	17
<b>10. Accessories.....</b>	<b>18</b>
<b>11. Guarantee.....</b>	<b>19</b>
<b>12. Parts subject to wear and tear .....</b>	<b>19</b>
<b>13. CE Declaration of conformity.....</b>	<b>19</b>

## 1. Safety regulations

### 1.1 Correct use / General safety instructions

The brushcutter must only be used to cut grass, reeds, weeds and wild growth **at ground level**. The brushcutter must not be used for any other purposes (see chapter 8.1 "Scope of Application").

 Before using the tool for the first time, make sure that you read these operating instructions and the separate operating instructions for the engine carefully. These operating instructions must be kept in a safe place. Always take great care when using this power tool.

Failure to comply with the safety instructions can have potentially fatal consequences. Please make sure that you also follow any health and safety regulations which apply. The operating instructions must always be kept together with the tool. Anybody who intends to work with or on the tool (including maintenance or servicing purposes) must read the instructions before doing so.

- You should request and receive instructions from the vendor on the safe operation if you are using this type of product for the first time.
- Children and young people under 18 years may not work with this power tool, with the exception of young people over 16 years of age who are being trained under supervision.
- Keep bystanders and animals away from the working area. Maintain a minimum distance of 15 m. When working near thickets, be aware that children and animals may be hidden there. Immediately stop the machine and the cutter if any person or animal comes close to the working area. The operator is responsible for any accidents or damage caused to parties or property.
- The device must only be lent, hired or passed on to persons who are familiar with this type of tool and who have read the operating instructions and know how to use the tool. Always pass on both sets of operating instructions together with the tool.
- Ensure you are rested and in good health when using this machine.
- Persons under the influence of alcohol or drugs, including prescription drugs, are not allowed to use this machine, as their ability to quickly react to potential danger may be impaired.
- Never alter, change or modify any safety equipment or functional assemblies on this machine.
- Only use this machine if it is in good, safe condition. Always check the machine prior to use. **Risk of accident!**
- Only use those accessories and attachments that have been supplied by the manufacturer and that are expressly approved for attachment. When using a nylon head, never replace a plastic line with a steel line. Always use the appropriate contact protection with each cutter.
- Always stop the engine and remove the spark plug cap when changing cutters to prevent unintentional starting of the engine.
- The reliability and safe operation of your machine depend on the quality of parts used with the machine. Only use original spare parts. Original spare parts are identical with genuine production parts and guarantee best quality in material, dimensions, function and safety. Original parts and accessories are available from your specialist dealer. Your dealer has been supplied with appropriate documentation to determine the correct parts. Your dealer is frequently supplied with updates about improvements to the equipment. Please note that the use of non-original parts will void your warranty.
- Always store the machine in a safe place and in such a way that it will not pose any danger. Stop the engine when the machine is not used.



Persons who disregard safety instructions, operating or maintenance instructions may be liable for any damage or consequential losses.

### 1.2 Working clothes

To prevent injuries, always wear suitable clothing and safety equipment when working with this power tool. This clothing should be practically oriented to the application (for example a tight fitting work suit), but should not be confining.

We recommend: **SOLO forest and countryside work jacket EN 340** Part no: 99303000 + size (2[s] - 6[xxl])  
**SOLO Outdoor Knee-breeches** Part no: 9902095 + size  
 or **SOLO Outdoor dungarees** Part no: 9902094 + size

Never wear scarves, ties, jewellery or other items of clothing, which might get caught in the equipment, in brush or on branches. Safely tie back long hair (use a cap, helmet or similar).

-  Wear sturdy shoes with a good tread - ideally safety shoes.  
We recommend: **SOLO leather forest boots** Part no: 9930510 + size (36 - 48)
-  Wear protective gloves with non-slip palms.  
We recommend: **SOLO Fit** Part no: 9939012 + size.
-  Use ear defenders and/or a visor for protection against flying objects or objects caught up in the turbulence (protective goggles for example).  
We recommend: **SOLO face/ear protection pack** Part no: 993901002 (one size)

### 1.3 Fuelling



Petrol is very light and highly flammable. Keep away from open flames and never spill fuel. Do not smoke at the operating site or at and near the refuelling site!

- Stop the engine prior to refuelling.
- Let the engine cool down before refuelling - fire risk!
- Open the tank lid slowly to allow any excess pressure in the tank to be reduced without the risk of petrol spraying out.
- Fuel may contain substances similar to solvents. Prevent products made from mineral oil coming into contact with skin and eyes. Wear protective gloves during filling with fuel. Frequently change and clean protective clothing.
- Avoid breathing in fuel vapour.
- The refuelling site should be well ventilated.
- Avoid any soil spillage of fuel or oil (protection of the environment). Use a suitable mat.
- Immediately clean any spilled fuel on the machine. Change contaminated clothing without delay.
- Firmly tighten all tank lids. This will reduce the risk of spillage from lids, which have become loose from engine vibrations.
- Check for petrol leaks. Do not start the machine or work with the machine if there is a petrol leak. Life threatening risk from burns!
- Store fuel and oil in approved and correctly labelled containers.

### 1.4 When transporting the equipment

- Always turn off the engine when transporting the machine.
- Never carry or transport the brushcutter with the engine running.
- Always cover the cutters with blade protectors, when transporting the equipment over longer distances.
- To prevent fuel running out and associated damages, secure the equipment against tipping over during vehicle transportation. Check the tank for leaks. It is advisable to drain the tank before transportation.
- Drain the tank before despatching the equipment.

### 1.5 Preparing the equipment for starting

Check the complete machine for operational safety.



- The stop switch should function properly.
- The throttle must have freedom of movement and return to the idle position on its own accord.
- The cutters and contact protection must be tightly secured and in perfect condition.
- Ensure the spark plug cap and the ignition cable are connected firmly. A loose connection may cause a spark, which can ignite any existing fuel:air mixture - fire hazard!

Should the check reveal any irregularities or recognisable damage (also to the frame), incorrect adjustments or reduced efficiency of the machine, do not commence work. Take the power tool to a specialised workshop and have it checked.

### 1.6 Starting

- Start the machine no less than 3 metres from the refuelling location. Never start the machine in an enclosed space.
- Ensure that you are standing firmly on the ground when starting. Always start on even ground, with a firm grip on the power tool.
- Only one person at the time may operate this power tool - no other people should be within a radius of 15 m - even when starting.
- Continue with the starting procedure as described in section 7. "Starting/Stopping the engine".

## 1.7 Working with the machine

- Only use this power tool when it is complete and in a safe condition.
-  As soon as the engine is running, the power tool generates toxic gases, which may be invisible and odourless.
-  Never work with the power tool in enclosed spaces. In confined conditions such as pits or excavations, ensure adequate air changes during work.
-  Do not smoke at the work site and in the immediate vicinity of the power tool. There is an increased fire hazard!
- Work conscientiously, thoughtfully and calmly, and do not endanger third parties.
  - Pay attention to good visibility and lighting conditions.
  - Always remain within earshot of other people who can provide help in case of emergency.
  - Plan for timely work breaks.
  - Pay attention to possible hazards and take appropriate precautions. Be aware that wearing ear defenders reduces the ability to perceive noise. This includes sounds alerting to danger such as signals, shouts, etc. that can go unnoticed.
  - Exercise caution when the ground is wet or covered in ice and snow, on overhangs, or uneven terrain. There is an increased risk of slipping!
  - Pay attention to the risk of stumbling and obstacles, such as tree roots and stumps, edges, etc. Pay particular attention to safety when working on slopes.
  - Before commencing work, check the working area for stones, broken glass, nails, wire or other solid objects and remove such debris to prevent them being picked up and thrown out by the cutters.
  - Always hold this power tool firmly in both hands, and ensure your safe and solid foothold.
  - Always hold the cutters below hip level. Never lift a rotating cutter off the ground.
  - Keep all parts of the body away from rotating cutters.
  - Use a correct operating mode (see Chapter "8.2 Correct brushcutter operation").
  - Use the power tool at lowest possible noise and exhaust levels. Only open the throttle when working, do not let the engine run unnecessarily. Please note that noise also impacts on the environment. Observe the quiet times that can vary from place to place.
  - Never use blunt cutters and avoid uncontrolled contact of the cutter with debris. Otherwise there will be an increased risk of the equipment kicking, which could throw the entire machine around. As a result, the operator could be subjected to involuntary movements, which could lead to serious injury or death.
- Stop the engine if you notice a difference in the operating characteristics of the brushcutter.
- Due to the centrifugal clutch, the cutters will run on for a short time, even if you release the throttle. Ensure the cutter has come to a full stop before storing the machine.
- Always stop the engine before any contact with the cutter – even when clearing a blockage or if cutters have become jammed – wait until the cutter has stopped and remove the spark plug cap.
- Never touch the exhaust or the silencer; as long as they are still hot, there is a risk of burns!
- Never work with a defective or missing silencer. There is a hazard of hearing damage and burning!

### **First Aid**

A first aid box should always be available on-site. Immediately replace any materials you have used:

Note:

Over exposing persons with circulatory problems to vibrations can lead to damage to their nervous system or blood vessels. The following systems may occur from vibrations to fingers, hands or the wrists: Numbness, itching, pain, twinges, changes to the colour of the skin or the skin itself. Seek medical advice if you experience any of these symptoms.

## 1.8 Maintenance and repairs

The power tool must be serviced on a regular basis. Only perform maintenance work or repairs yourself if the work is described in these operating instructions or in the separate operating instructions for the engine. All other work must only be performed by an authorised workshop.

- Do not maintain, repair or store the machine near an open flame.
- Before cleaning, maintenance and repair work, always stop the engine first and pull the spark plug cap. Exceptions: carburettor and idle adjustments.
- For any repairs only use original parts from the manufacturer.
- Do not modify, alter or change the machine as this may impact on the safe operation of the machine and may lead to accidents and injuries!

## 2. Standard delivery

- **Engine block on the backpack carrier frame**
- **Flexible shaft with corrugated hose retainers**
- **Shaft tube with female connection to the flexible shaft, loop handle, multi-function handle** (incl. throttle, stop switch and half-throttle detent), **corrugated hose** (incl. electric and Bowden cable) and **gearbox**
- **Shield**, protective bar (line trimmer assembled) and all parts required to assemble the shield
- **Cutting tool:** (model-specific, for metal cutting blades this also includes a corresponding transport protector)
- All **assembly parts** required to fit the grass cutter blade and the nylon head (all models)
- **Tools:** combination spanner, retaining pin and screw driver
- These **operating instructions** and the separate **engine operating instructions**

## 3. Control and function elements

Fig. 1

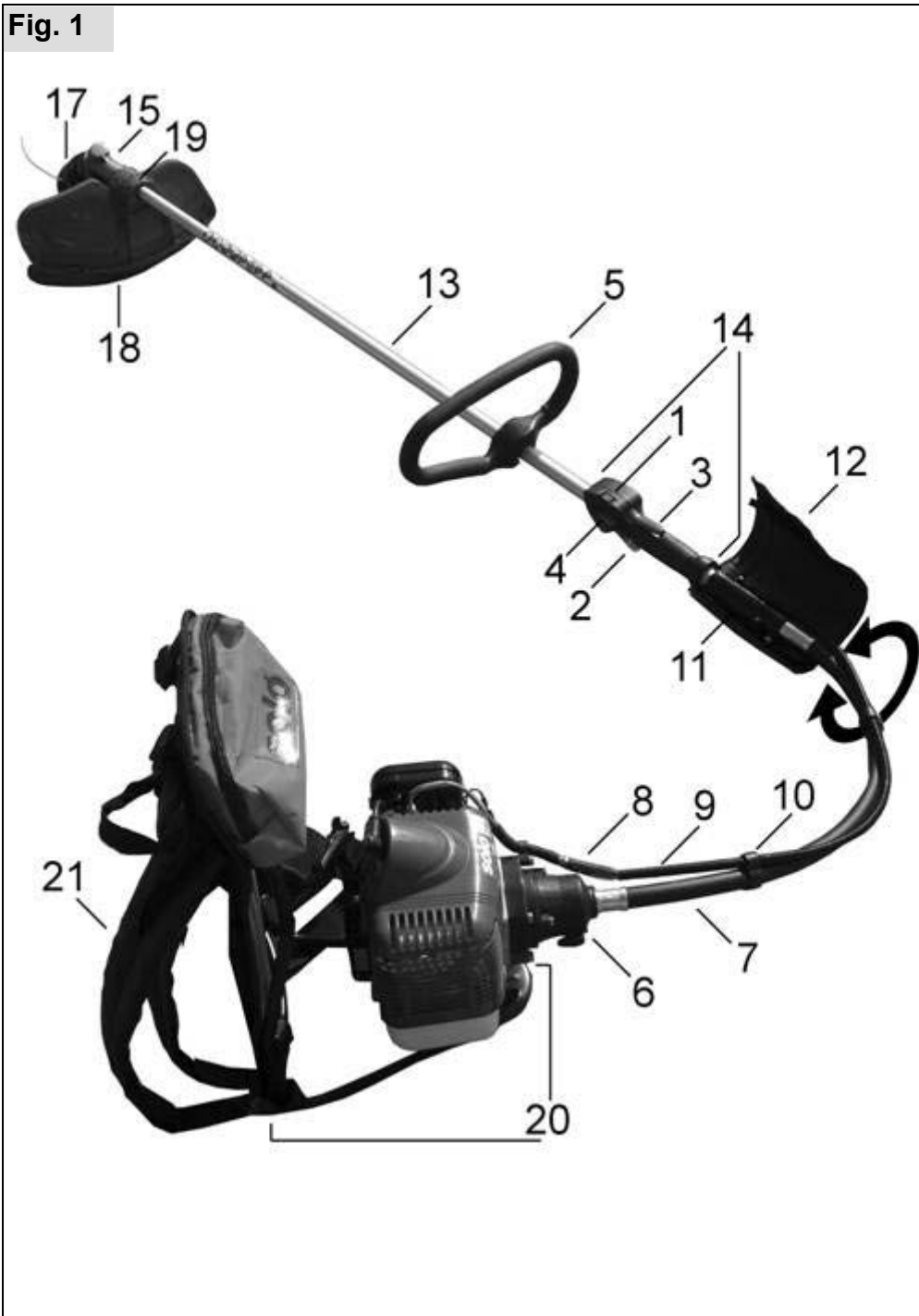

1 Stop-switch

2 Throttle lever

3 Throttle lock

4 Half throttle lock

5 "Loop" handle

6 Engine flange with clamping lever

7 Flexible shaft

8 Cable connection casing

9 Corrugated hose (incl. electric and Bowden cable)

10 Corrugated hose retainer

11 Female connection

12 Thermal insulation

13 Shaft tube

14 Handle

15 Gearbox

17 Cutter

18 Shield

19 Retainer

20 Backpack carrier frame

21 Carrier straps

## 4. Specification

Brushcutter		149
Engine type		Kawasaki single cylinder two-stroke engine
Engine capacity	cm <sup>3</sup>	48,6
Bore / stroke	mm	44 x 32
Engine power	kW at rpm	2,2 / 7000
Fuel tank capacity	l	1,0
Gear reduction		1,23:1
Shaft tube / Drive shaft /Star serration	Ø mm	28 / 8 / 9 teeth
Weight w/o shield and cutter	kg	10,9
In determining the following values regarding the acceleration of vibrations and sound, the different operating conditions were weighted in accordance with the current standards.		
Weighted effective acceleration $a_{hv,eq}$ (DIN ISO 22867) Handle r.h. side / handle l.h. side		
Nylon head	m/s <sup>2</sup>	2,99 / 3,51
Grass cutter blade 4 teeth	m/s <sup>2</sup>	3,32 / 3,73
Cutter head "Jet-Fit"	m/s <sup>2</sup>	2,26 / 2,65
Sound pressure level $L_{Peq}$ (EN ISO 22868)		
Nylon head	dB(A)	93,2
Grass cutter blade 4 teeth	dB(A)	92,8
Cutter head "Jet-Fit"	dB(A)	91,0
Sound power level $L_{Weq}$ (EN ISO 22868)		
Nylon head	dB(A)	105,6
Grass cutter blade 4 teeth	dB(A)	105,0
Cutter head "Jet-Fit"	dB(A)	104,8

## 5. Preparing the equipment for use

For shipping purposes, the brushcutter is partly disassembled and has to be reassembled prior to use.

Only use the brushcutter after it has been fully assembled.

Ensure that the tank is fully drained before any assembly, disassembly or modification.

### 5.1 Loop Handle

The longer side of the handle serves as a safety barrier and must therefore always be on the side of the user:

(Arrow marking Fig. 2).

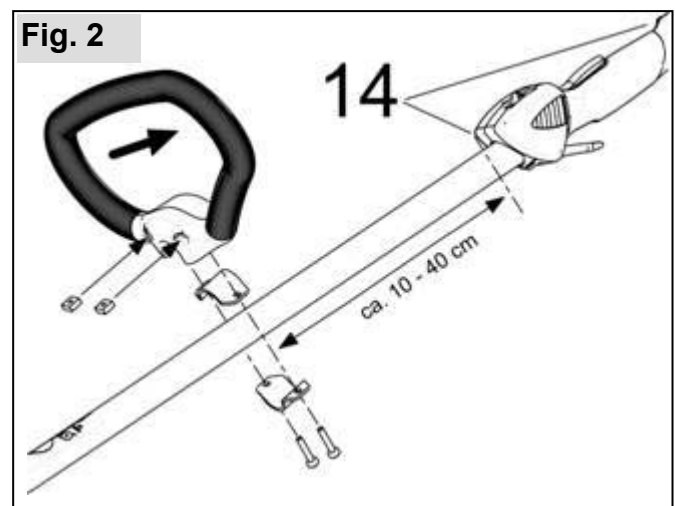

- Install the loop handle on the shaft tube, approx. 20 cm - 40 cm in front of the right-hand multifunctional handle.
- Tighten the screws.



## 5.2 Shield installation

When assembling the guard, the damping inserts from the accessories pack must be fitted into the guard and mounting bracket in accordance with Figures 3a - 3e below.

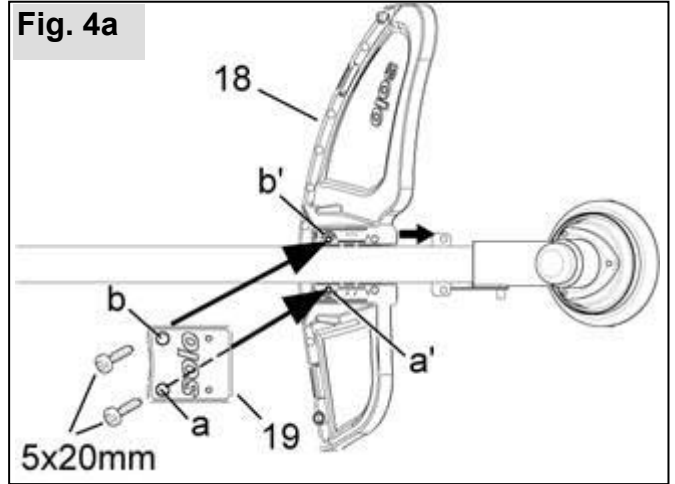
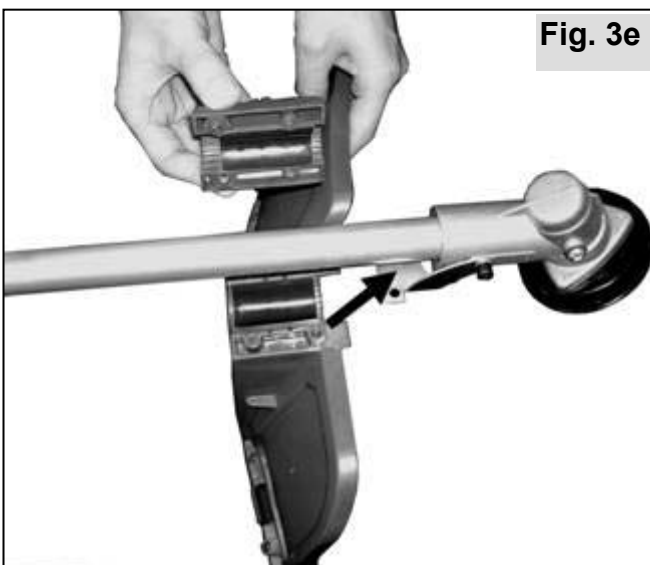
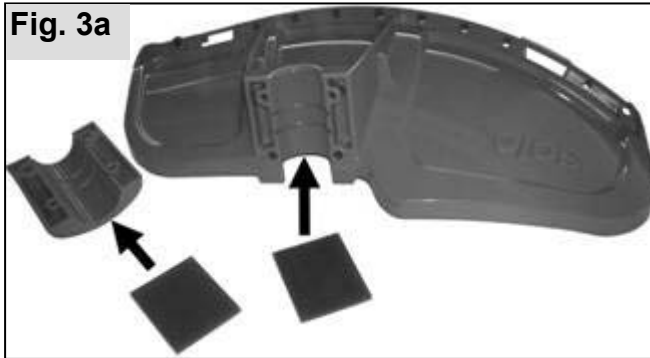

Position the brushcutter with the output shaft facing downward.

- Raise the shaft tube and slide the guard (18) along the underside of the shaft tube into the correct position (it should reach a stop at the angular gearbox).
- Lay down the shaft tube with the guard.
- First insert a 5 x 20 mm bolt through hole **a** to tighten the retainer (19) on the guard. Then insert the second 5 x 20 mm bolt through hole **b**, tightening finger tight only at this stage.

(**Note:** The retainer has a raised part on the inside near hole **a**. This allows the first bolt (which is inserted through hole **a**) to be tightened straight onto the block without any risk of the connection not being straight.)

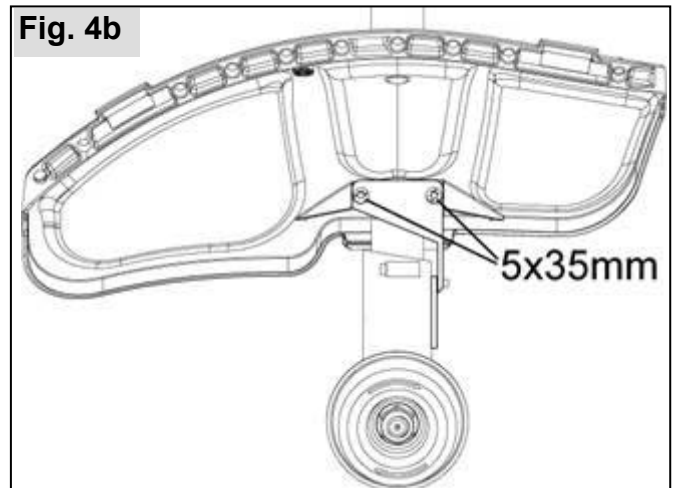

- Reposition the brushcutter with the output shaft facing upward.
- Insert the two long 5 x 35 mm bolts through the hole on the retaining bracket of the angular gearbox and tighten the guard and the retainer. The holes must line up exactly, so it may be necessary to adjust the position of the guard first.
- To finish off, fully tighten the bolt in hole **b**.

### 5.3 Cutter installation

Always switch off the engine, pull the spark plug cap and wear protective gloves when fitting or replacing the cutter!

Depending on your particular model, one of the following cutting tools will already be provided as standard equipment with your brushcutter. The cutting tools described below are available as genuine SOLO replacement parts which can be obtained from specialist retailers and should be installed as described below. Please refer to the overview of approved accessories in chapter 10 for more information.

#### A) Assembly of the 4-tooth grass cutting blade

Fig. 5

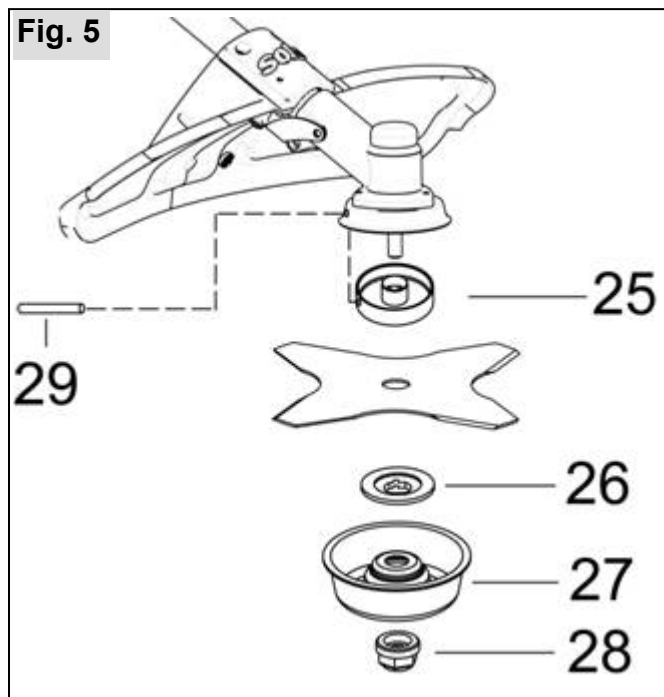

- Position the brushcutter with the output shaft facing upwards.
- Place the brush cutting blade on the pressure piece (25). In order to centre the cutting blade, the shoulder of the pressure piece must be located exactly in the bore of the cutting blade.
- Fix the pressure washer (26).
- Place the nut protector (27) and turn safety nut (28) onto the shaft.

Caution! Left hand thread - tighten counter clockwise.

Take care that all parts are centered.

- Block the shaft with the stop pin (4) and tighten nut.

 It is imperative that the safety nut (28) is replaced, if it has become loose due to frequent removal and tightening.

Afterwards check that the cutting blade is securely seated and that it is properly centred.

#### Transport protection for metal cutting blades

When you first purchase an approved metal cutting blade which is not supplied together with the brushcutter (see chapter 10 "Accessories"), you will also need to purchase a corresponding transport protector.

When the metal cutting blades are attached (4-tooth grass cutting blade provided either as standard equipment with the different models or purchased as accessories), the transport protector must always be attached to cover the blades when the device is being stored or transported, or during work breaks during which the engine is switched off.

Fig. 6

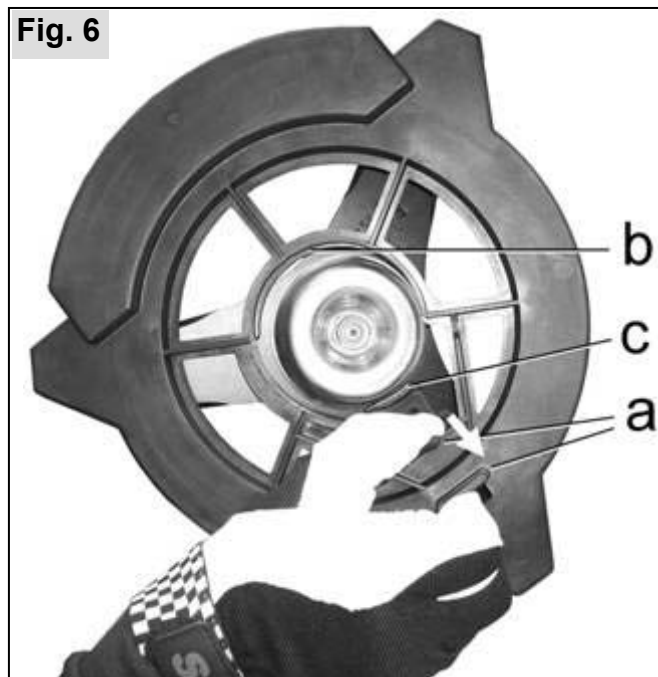

- Position the transport protector with the corresponding recess at one of the tips of the metal cutting blade.
- Press the two tabs (a) on the transport protector together to increase the internal diameter of the transport protector.
- Lay the transport protector right over the cutting tool. Position the inner shoulder (b) between the metal cutting blade and the running disc.
- Open the two tabs again, and in doing so also position the inner shoulder between the metal cutting tool and the running disc at tab (c).

When restarting work, take the transport protector back off by pressing the two tabs (a) together before starting the engine.

## B) Assembly of the nylon line head

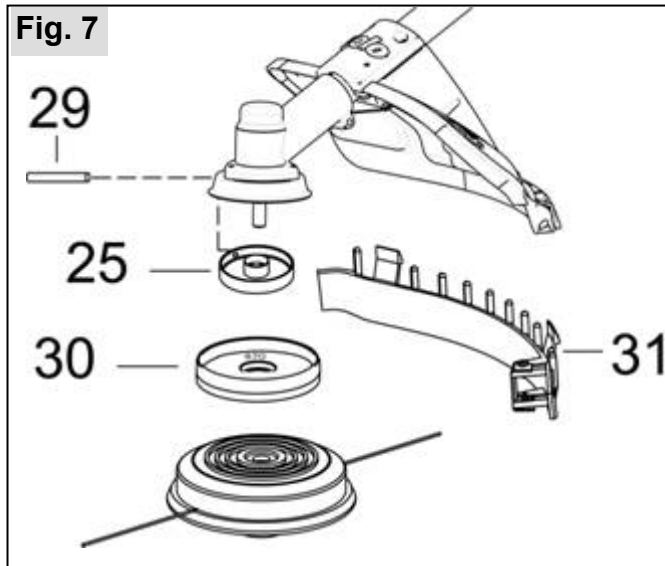

When fitting a nylon line head, you will not need the following components shown in Fig. 5:

Retaining nut (28) (caution: left-handed thread), nut protector (27), pressure washer (26) and metal cutting blade.

- Fit the anti-winding protection (30) (supplied with the line head) after the pressure piece (25). The side of the anti-winding protection labelled with the number "870" faces the gearbox, so the edge of the anti-winding protection overlaps the edge of the bevel gearbox.
- Block the shaft with the pin (29).
- Screw on the line head by hand. Caution: left-handed thread.
- Fit the protective bar (31) with assembled line trimmer from underneath onto the guard. Bend the protective bar slightly in the process.

**⚠ Important:** When using the line head, never start the brushcutter without the protective bar and the line trimmer assembled.

If the length of the line has been adjusted (see chapter 8.3, "Adjusting the cutting line"), the line trimmer will automatically cut the ends of the line to the correct length during operation.

When using metal cutting blades, always work without the protective bar fitted.

## C) Assembly of the "Jet-Fit" cutting head



Insert the cutting line into the main body of the cutting head in accordance with the arrows on the main body. Insert enough line so that approx. 20 mm of the cutting line protrudes from the opening on the

opposite side.

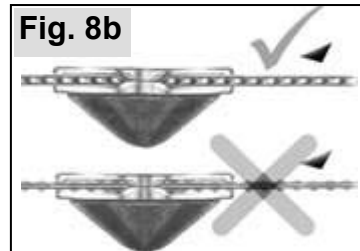

Make sure that the cutting teeth are correctly aligned in the direction of rotation.

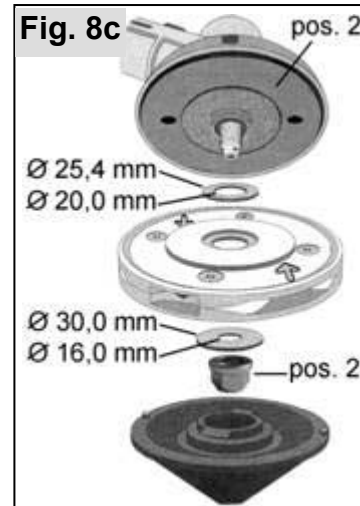

Various washers are supplied with the cutting head. For installation on this type of brushcutter, use exactly the washer dimensions shown in the illustration (outer diameter, inner diameter). The lower washer with an inner diameter of 16 mm must be positioned around the splines on the shaft.

Block the shaft with the pin (29) and tighten the nut (28). Check that the cutting head is securely seated and properly centred.

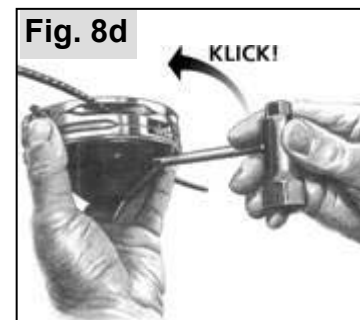

Fit the cover of the cutting head in place, turn it in the direction of the arrow and tighten it with the combination wrench as shown in the illustration until it engages.

When using the "Jet-Fit-Flexiblade" cutting head, always use the standard guard and the assembled protective bar.

Cutting lines must not touch the guard during rotation. If necessary, insert the cutting lines slightly further into the main body of the cutting head. The line trimmer which is assembled in the protective bar is not suitable for cutting lines. → The length of the cutting lines needs to be manually adjusted to the correct length.

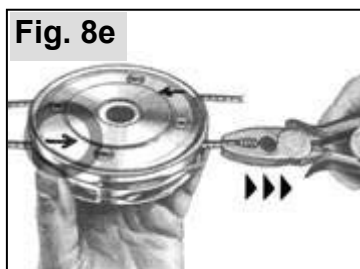

To replace a cutting line, pull the protruding end back out from the main body in the direction of the arrow (use universal pliers if necessary).

### 5.4 Fitting the flexible shaft to the female connection

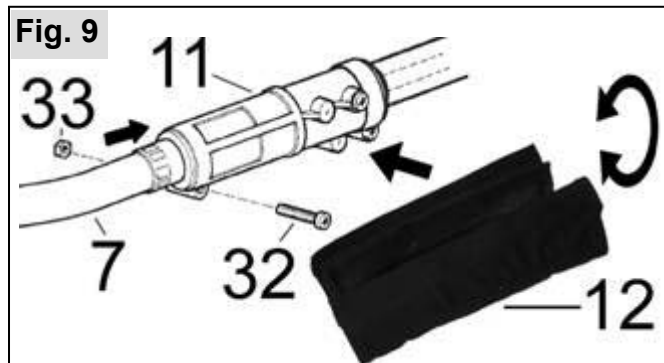

- Pull off the red protector from both ends of the flexible shaft (7).
- Insert the flexible shaft until it bottoms out inside the female connection (11), and secure with screw (32) and nut (33). The drive shaft quadrant must grip into the driver of the female connection.
- Fit the thermal insulation (12) over the clutch coupling.

### 5.5 Fitting the flexible shaft to the motor flange

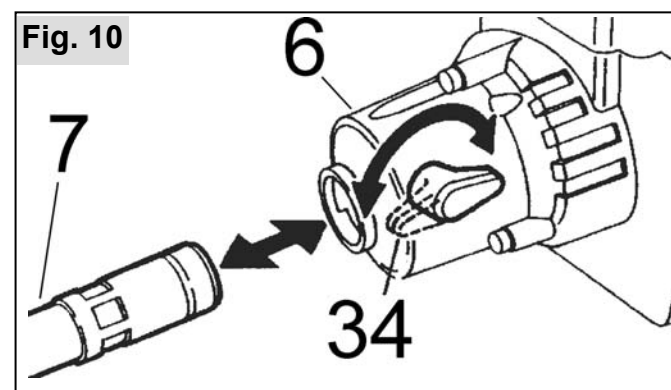

- Pivot the clamping lever (34) forward at the engine flange (6) and hold it there.
- Insert the flexible shaft (7) until it bottoms out.
- Release the clamping lever.

### 5.6 Electric and Bowden cable connections

- Push the corrugated hose retainers (10) onto the flexible shaft.
- Insert the corrugated hose (incl. electric and Bowden cable) (9) through the corrugated hose retainers.



- Open the lid of the cable connection casing (8).
- hook in the Bowden cable,
- close the lid.

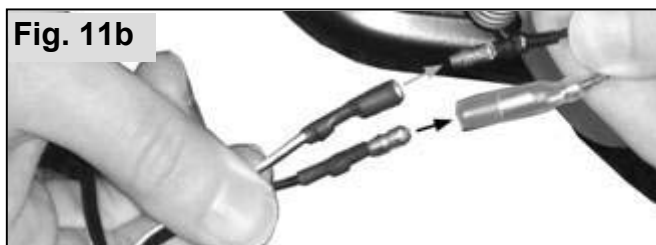

- Connect the electric plug-in connection.
- ⚠** Under no circumstances must the corrugated hose be under tension, otherwise the engine will not run smoothly and the cutting tool may start up when the throttle has not yet been pushed in – **Risk of accidents!** Therefore, check before commencing work that in the throttle idle position, the hook-in lever at the carburettor is slack and touching the idle end stop screw.

## 6. Fuelling

**Always comply carefully with the specifications in the separate operating instructions for the engine.**

A high performance two-stroke engine operated with a petrol:oil mixture (petrol + oil = fuel mixture) or with a special fuel mixture for two-stroke engines available from specialists powers this machine. Unleaded normal petrol can be used for the fuel mix.

Unsuitable petrol or deviations in the mixing ratio may lead to serious engine damage!

**⚠** Avoid direct skin contact with petrol and avoid inhaling petrol fumes - health hazard!

Mixing ratio:

We recommend a mixture of 1:50 (2%) when using our special 2-stroke oil "**SOLO Professional 2-stroke Engine Oil**".

Order no.: 1-litre pouring bottle 0083105

#### Fuel mixture table

Petrol in litres	Oil in litres
	SOLO 2T engine oil 2% (1 : 50)
1	0,020
5	0,100
10	0,200

Never store fuel mixture longer than 3 - 4 weeks.

## 6.1 Fuelling

While fuelling always follow all safety instructions and take all safety precautions.

Handle fuel only with the engine turned off. Carefully clean the area around the filler inlet. Place the machine with the fuel inlet pointing upwards. Unscrew the tank lid and fill the fuel mixture up to the lower edge of the filler neck. Use a funnel with filter to prevent tank contamination. After filling the tank replace the tank lid and tighten firmly.

## 7. Starting / Stopping the engine

### 7.1 Half throttle start position

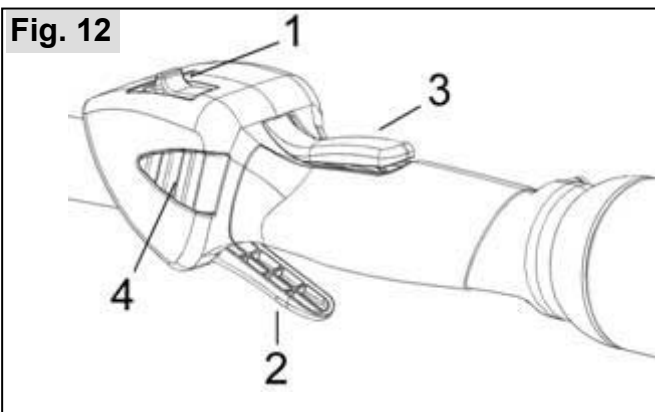

- Slide the stop switch (1) into the operating position.
- Grip the handle; the **safety locking key** (3) is activated via the grip area, which also enables **throttle lever** (2) to be regulated.
- Press **throttle lever** fully down.
- Press the half throttle lock (4), and let the throttle lever return, whilst holding the half throttle lock in.

### 7.2 Startup settings on the engine

**Precise details for your engine type can be found in the separate engine operating instructions.**

#### Primer (model-specific):

When starting the engine for the first time or when starting the engine after the tank has been run dry and then refuelled, repeatedly press the **primer** to pump fuel to the carburettor. Any excess fuel which is pumped into the carburettor is automatically returned to the tank.

#### Choke lever (model-specific):

If the engine is cold, use the choke lever to close the starter flap before starting up the engine for the first time (↔). Pull the starter rope a maximum of three times until the engine audibly starts up for the first time. Then it is very important to open the starter flap again via the choke lever (↕). Keep starting the engine until it runs.

Please note: Do not attempt to start the engine more than three times when the starter flap is closed, as otherwise the combustion chamber will be flooded

with fuel, which will make it much harder to start the engine.

We recommend the following procedure if the engine is flooded in this way and it is difficult to start the engine:

- Remove the spark plug and dry fuel mixture from the electrodes.
- Move the throttle lever up to full throttle. Pull the starter handle several times (with removed spark plug) to clear the combustion chamber.
- Move the throttle lever down to idling position, refit the spark plug, the plug cap and the plug cover.
- Start the engine with the part throttle stop set and the choke lever set to the "open" position (↕).

### 7.3 Starting

Observe the safety instructions when starting.

Lay the brushcutter level and without obstructions on the ground.

During starting, never stand or kneel on the shaft tube, otherwise the shaft or the tube might be damaged.

Take up a safe position, securely hold the machine and ensure that the cutter does not touch any objects or the ground.

Move the stop switch to the operating position.

**Note:** Under good conditions, the engine will already start under idling throttle if it is at operating temperature. (If a part throttle stop is set it will be cancelled by operation of the throttle control even if the engine is at standstill.)

Set the part throttle stop as described above for all cold starts or if the engine fails to start with the throttle lever in idling position..

The following instructions are aimed at increasing the service life of the starter rope and of the starter mechanism:

- Always pull the rope out in a straight line.
- Do not let the rope drag across the edge of the rope eyelet.
- Do not pull rope all the way out - risk of the rope breaking.
- Always manually guide the rope back into its start position with your hand on the starter grip - do not let it retract on its own.

A specialist can replace a damaged starter rope.

If the engine is running in part throttle operation: briefly pull the throttle back to release the half throttle detent. Release the throttle lever again to allow the engine to run at idle speed. Now you can commence working.

## 7.4 Turning off the engine:

Release the throttle and push the stop switch to "STOP".

**Important:** Due to the centrifugal clutch, the cutter will run on for a short time, even if you release the throttle. Ensure the cutter has come to a full standstill before storing the machine.

**Emergency stop** Should the engine – due to a faulty ON / OFF switch – fail to stop, it can also be stopped by closing the choke (choke lever in position  $\leftarrow$ ).

**After such an event, do not restart the engine, but have the equipment checked by an authorised service shop.**

## 8. Using your brushcutter

### 8.1 Scope of Application

Only use brushcutters equipped with a nylon head (subject to model) for cutting grass – particularly suitable around obstacles - and for trimming light weeds and wild growth near ground level. The nylon head is particularly suitable for a soft cut, e.g. for clean trimming around trees and posts.

Use brushcutters equipped with the grass cutter blade (subject to model) only for cutting grass away from obstacles and for cutting stronger weeds and wild growth near ground level.

Never use the brushcutter for any other purpose.

Using the cutting tools, which are available as accessories and which are specified for certain tasks, enable the brushcutter to be used for those purposes specifically mentioned in the accessory instructions. Also observe the safety instructions in those accessory instructions.

Generally, use only the cutting tools authorised for use with this brushcutter. Always fit the contact shield specified for this brushcutter and cutting tool. If in doubt, contact your local SOLO dealer.

### 8.2 Correct brushcutter operation

Observe the relevant safety instructions when using the brushcutter.

Always lead the power trimmer on the r.h. side of your body.

The rotational direction of the cutting tool makes the operation on the l.h. side of the cutting tool (from the operator's viewpoint, subject to the brushcutter being held correctly) particularly free from kicking.

Therefore, always approach the area to be cut from the right. This brings the l.h. side of the cutting tool into contact with the material to be trimmed first.

Particularly when cutting tougher growth (such as medium sized weeds and wild growth) with a grass cutter blade, ensure that you do not "stab" the front of the brushcutter into the material to be trimmed.

Fig. 13

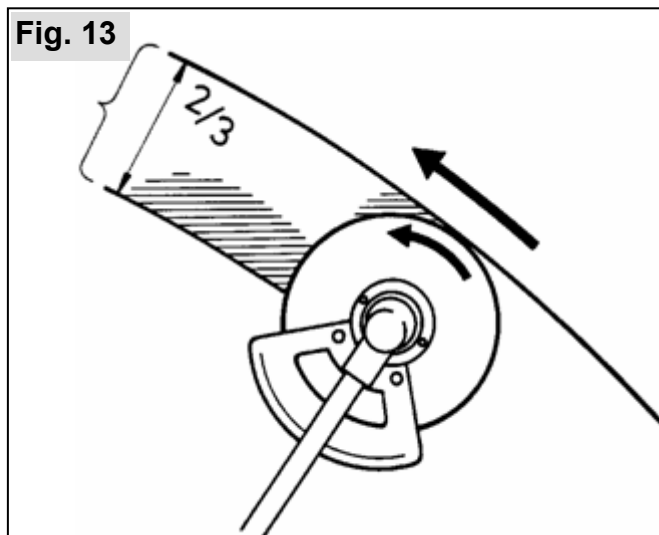

Approach the working area with the brushcutter set to idle, and then switch to full throttle. Never leave the engine running at high speed without applying a load.

Dip the tool from the r.h. side 2/3 into the material to be trimmed. Then work the brushcutter like a scythe, i.e. by moving forward step by step, whilst cutting from right to left.

Operate the brushcutter at full throttle to obtain an optimum cutting result. Never operate with the clutch in slipping range. Consequential damage through excess loads or overheating is excluded from our warranty.

Immediately stop the engine in case of noticeable vibrations or when material has gathered around the cutting tool or contact shield. Slow down the cutting tool by pressing it onto the ground, until it has come to a complete standstill. Pull the spark plug cap from the plug, and clean the tool seat of all grass, roots etc. Check the entire brushcutter for perfect condition.

When using the nylon head (Accessory No.: 69 00 652 6), always ensure that you operate only with the correct length of line. When the contact shield is fitted, the line will always be trimmed to the permissible length automatically (a line trimming blade is fitted into the shield). There is a high risk of injury, and the engine is subjected to excessive loads leading to a risk of damage, if nylon lines are left too long.

Therefore, when converting the cutting tool from grass cutter blade to nylon head (Accessory No.: 69 00 652 6), always fit the standard contact shield together with the protective bar and fitted line trimming blade.

### 8.3 Note on using the nylon line head (available as accessory)

When using the nylon head, always ensure that you operate only with the correct length of line. When the contact shield is fitted, the line will always be trimmed to the permissible length automatically (a line trimming blade is fitted into the shield). There is a high risk of injury, and the engine is subjected to excessive loads leading to a risk of damage, if nylon lines are left too long.

**⚠ Important:** When using the line head, never start the brushcutter without the protective bar and the line trimmer assembled.

#### Adjusting the cutting line

When using a semi-automatic nylon head:

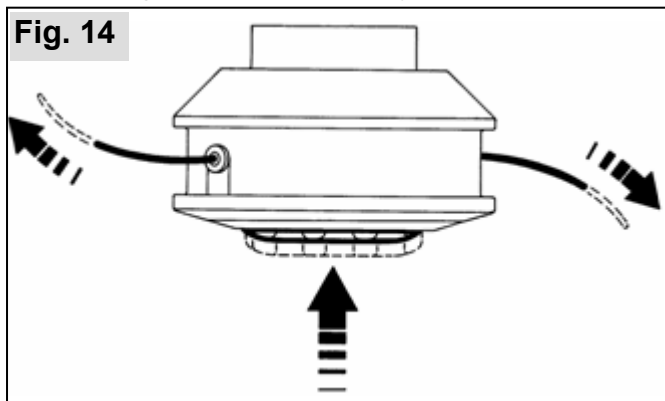

(schematic diagram)

Whilst the brushcutter is running without load, but with rotating nylon head, lightly push the nylon head several times onto ground with growth cover. The cutting line will be dispensed in stages. With each action, approx. 30 mm line will be dispensed. The line trimming blade will correct any excess length. When the cutting line is fully spent, you can replace it with line available

Ø 2,4 mm under part no. 6900942

or

Ø 3,0 mm part no. 6900974 (accessory).

## 9. Operating and maintenance instructions

### 9.1 General operating and maintenance instructions

The maintenance and the repair of modern machines as well as their safety-relevant assemblies require qualified specialised training and a workshop equipped with special tools and test equipment. Consequently the manufacturer recommends that all tasks not described in these operating instructions be carried out by a specialised workshop. That specialist has the required training, experience, and equipment at his disposal, to provide you with the most cost-effective solution for such work. He will provide additional help in word and deed.

After a running-in time of app. 5 hours, all accessible screws and nuts (except the carburettor adjusting screws) must be checked for tightness and they must be retightened, if required.

Check the cutter regularly and whenever you notice any irregularities, or when the cutter/contact shield becomes blocked. For this, switch off the engine and wait until the cutter has come to a complete standstill. Pull the spark plug cap, and remove grass, debris, etc. from the cutter support. Immediately replace blunt or damaged tools, even if they display only small cracks – do a "ping" test.

It is best to store the equipment in a dry, safe location with a full fuel tank. There should be no open flame or similar nearby. For longer periods without using the equipment (longer than four weeks), see chapter "9.4 Shutdown and storage".

### 9.2 Lubricating the flexible drive shaft

It is recommended to check the lubrication of the flexible drive shaft before the start of each new job. When required, but no later than after every 5 hours, remove the flexible drive shaft from the flexible shaft and replenish its lubrication.

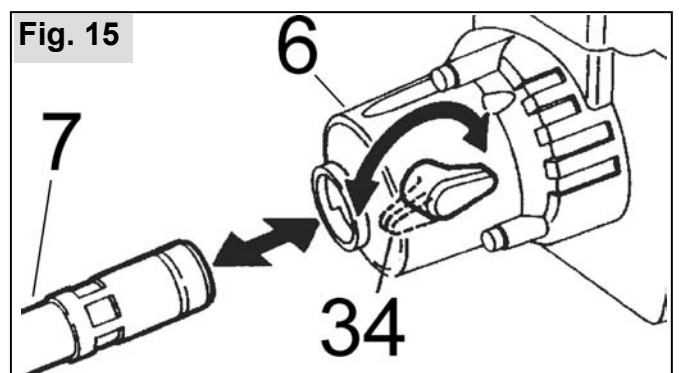

Pull the flexible shaft (7) off the engine flange (6) after moving the locking lever (34) forward.

You can then remove the flexible drive shaft from the flexible shaft (7).

Use commercially available general purpose grease, that is temperature-resistant, to lubricate the shaft.

During the assembly, ensure that the flexible shaft fully engages the engine flange.

### 9.3 Gearbox lubrication

To lubricate the bevel gear drive, use SOLO "Special gearbox grease" (part no. 008318025). Check the grease level weekly and top up, if required (approx. every 20 - 50 hours).

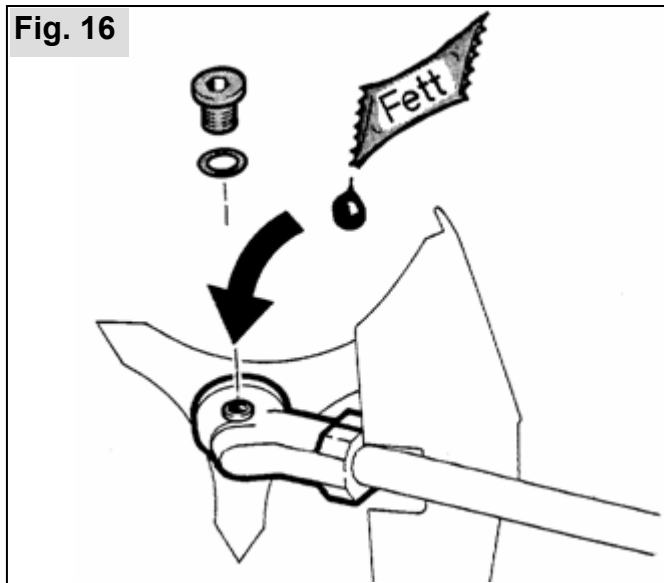

(schematic diagram)

Remove the filler plug from the side of the gearbox. If no grease is visible inside, top up with grease (top-up quantity approx. 5 – 10 g).

Replace and tighten the filler plug.

**Please note:** Do not overfill with grease, as that may lead to the gearbox overheating. Never fill the gearbox casing to the top with grease.

**Tip:** If required, top up with a maximum of 5g grease. It is preferable to check more frequently (e.g. before you start working) whether grease is still visible.

Your SOLO dealer workshop is happy to help you in case of doubt.

### 9.4 Engine components

When performing adjustments or maintenance work on engine components, always carefully follow the specifications in the separate operating instructions for the engine. Only perform work which is actually described in the instructions and which you feel able to carry out. All other work must only be performed by an authorised specialist workshop, who will also be happy to assist with any queries.

The following work is the minimum level of work which must be performed on a regular basis in accordance with the specifications in the operating instructions for the engine:

- Check the idling position and readjust the idling stop screw as required.  
No drive must be delivered to the cutting tool when the engine is idling.
- Clean the air filter and check the filter element.
- Check the silencer **before** starting work and **before** starting the engine to check it is in perfect condition.  
Never touch the silencer when it is hot.
- Check the spark plug to make sure that the electrode gap is correct and the electrodes are not excessively burned off.
- Check the fuel tank breather and the fuel filter.

### 9.5 Shutdown and storage

Preferably, store the equipment in a dry and secure place with a full fuel tank. Open flames or similar must not be nearby. Prevent unauthorised use – particularly by children.

For stops longer than four weeks the following steps should be carried out:

- Empty and clean the fuel tank at a well-ventilated location.
- Start the engine with an empty fuel tank. Run the engine until the carburettor is empty and the engine stalls. Otherwise the carburettor nozzles could become encrusted with residual fuel mixture and make a subsequent start harder.
- Clean the power tool well (particularly the air intake openings, the cylinder fins, the air filter and the fuel filler area).
- Preferably, store the equipment in a dry and secure place with a full fuel tank. Open flames or similar must not be nearby. Prevent unauthorised access – particularly by children.



## 9.6 Scheduled maintenance

The following information is based on standard operating conditions. For special conditions, such as prolonged daily use, the recommended maintenance intervals should be reduced accordingly.

		after the first 5 hours	before starting work	Weekly (approx. every 5 hours)	after every 50 hours	after every 100 hours	as required	before the start of the mowing season, or once per year
<b>Lubricating the flexible drive shaft</b>	Check		X					X
	Top up			X			X	X
<b>Carburettor</b>	Check idling speed		X					
	Adjust idling speed						X	
<b>Air filter</b>	Clean		X					
	Replace						X	
<b>Spark plug</b>	Check the electrode gap and adjust, if required				X			X
	Replace					X	X	
<b>Gearbox lubricant</b>	Check			X				X
	Top up				X		X	X
<b>Metal cutting blades model-specific / accessory</b>	Check		X					
	Sharpen						X	
	Replace						X	
<b>Cooling air inlet</b>	Clean			X			X	X
<b>Cylinder fins</b>	Clean						X	X
<b>Fuel tank</b>	Clean				X			X
<b>Fuel filter</b>	Replace							X
<b>All accessible screws (except for adjusting screws)</b>	Retighten	X					X	X
<b>Controls (stop switch, throttle lever, half throttle detent, starter)</b>	Check function		X					
<b>Silencer</b>	Visual inspection		X					
<b>Complete machine</b>	Visual inspection		X					
	Clean			X			X	X

Implement all maintenance jobs regularly. If required, authorise a specialist service centre to maintain the machine for you. The owner of the machine is responsible for:

- Any damage caused by a lack of maintenance, incorrect or late maintenance and repairs
- Consequential losses - including corrosion - from incorrect storage

## 10. Accessories

Via dealers, SOLO offers an extensive range of brushcutter accessories. Their use is limited to the particular model to which it is allocated, together with its relevant protection. Please refer to the following table for the approved accessories, and check with your retailer.

Accessory	Protection	Part no.
2 <b>nylon head</b> semi-automatic. M 10 x 1.25 Left (grass, even around obstacles, light weeds)	Standard protection + protective bar,line trimming blade	69006526
<b>Replacement line</b> for nylon head 15m, Ø2.4 mm		6900942
<b>Replacement line</b> for nylon head 15m, Ø3.0 mm		6900974
<b>Spool of nylon cord</b> 90 m, Ø2,4 mm		0063201
<b>Grass cutter blade</b> 4 teeth, Ø230 mm (grass, stronger weeds)	Standard protection	6900948
<b>Transport protector</b> for metal cutting blades up to Ø250 mm		6073543
2-line- <b>Cutter head</b> "Jet-Fit " (bushes, reeds, tough grass, branches up to 20mm)	Standard protection + protective bar,line trimming blade	6900160
<b>Replacement line</b> for "Jet-Fit " cutter head 2.5 mm x 260 mm 50 pcs.		6900166
<b>Replacement line</b> for "Jet-Fit " cutter head 3,5 mm x 260 mm 25 pcs.		6900168
<b>Replacement line</b> for "Jet-Fit " cutter head 2,5 mm x 53 m		6900175
<b>Replacement line</b> for "Jet-Fit " cutter head 3,5 mm x 27 m		6900176
High performance <b>gearbox grease</b>		008318025
SOLO 2T engine oil 100 ml		0083103
SOLO 2T engine oil 1 l		0083104
SOLO 2T engine oil, in a metering bottle 1 l		0083105
SOLO face/ear protection pack		993901002
SOLO forest and countryside work jacket EN 340	99303000 + size (2[s] - 6[xxl])	
SOLO Outdoor Knee-breeches		9902095 + size
SOLO Outdoor dungarees		9902094 + size
SOLO leather forest boots		9930510 + size (36 - 48)
Gloves SOLO Fit		9939012 + size

## 11. Guarantee

The manufacturer guarantees trouble-free quality and will cover the cost of replacing parts which are found to be faulty in material or workmanship within the prescribed guarantee period after the date of purchase. Please note that specific guarantee conditions may vary from country to country. If in doubt, ask your equipment vendor. He is responsible for guarantee matters.

We hope you will understand that we cannot be liable for damage resulting from the following causes:

- Non-compliance with the operating instructions.
- Neglecting essential maintenance and repair work.
- Damage caused by incorrect carburettor adjustment.
- Wear in normal use.
- Obvious overload by continuously exceeding the maximum performance limit of the product.
- Using non-authorized tools.
- Use of force, incorrect treatment, misuse and accidents.
- Damage from excessive heat due to dirt build-up around the cooling fan housing.
- Attempted adjustments and repairs by unqualified persons.
- Use of unsuitable spare parts or third party parts, if these are the cause of the defect.
- Use of unsuitable or stale fuel.
- Damage caused by using the product in the hire or rental industry.

Normal cleaning, adjustments or maintenance work fall outside the guarantee provisions.

A service centre authorised by the manufacturer must carry out all guarantee work.

## 12. Parts subject to wear and tear

Various parts are subject to application-specific or normal wear and must be replaced in good time, when required. The following parts are subject to normal wear and are not covered by the manufacturer's guarantee:

- Air filter
- Fuel filter
- All rubber parts which come into contact with fuel
- Clutch
- Spark plug
- Starter
- Cutting tools

## 13. CE Declaration of conformity

In accordance with EG Directives 98/37/EC, 2000/14/EC and 89/336/EEC (amended by 92/31/EEC), SOLO Kleinmotoren GmbH, Stuttgarter Strasse 41, D-71069 Sindelfingen, being solely responsible, states that the product referred to in this declaration complies with the requirements of the Machinery Directive.

Description of product: Brushcutter

Model/type description:: **149**

Sound power level

( ISO 3744,	Guaranteed sound	110	dB(A)
ISO 22868)	Actual sound	108	dB(A)

Applied standards:: ISO 12100, ISO 14865, ISO 14982

Conformity assessment procedures (2000/14/EG) → Appendix V

This declaration of conformity loses its validity, if the equipment is converted or modified without the manufacturer's consent.

Sindelfingen, 1<sup>st</sup> January 2007  
SOLO Kleinmotoren GmbH

  
Wolfgang Emmerich  
Executive Director

# **solo**<sup>®</sup>

Made in Germany and Japan



SOLO  
Postfach 60 01 52  
D 71050 Sindelfingen  
Tel. 07031-301-0  
Fax 07031-301-130  
info@solo-germany.com

SOLO  
P.O.Box 60 01 52  
D 71050 Sindelfingen  
Germany  
Phone+49-7031-301-0  
Fax +49-7031-301-149  
export@solo-germany.com