

solo[®]

106

Instruction manual

Brushcutter

Important!

Read this instruction manual carefully before first operation and strictly observe the safety regulations!



Dear Customer,

Congratulations for choosing this SOLO quality product.

The proven technology used in the Nikasil-coated vertical cylinder 2-cycle engine guarantees high performance and low fuel consumption.

Prior to operating the unit, please read the owner's manual carefully, and most importantly, observe all safety rules.

In order to maintain the performance of the brushcutter, it is necessary to carefully follow the service instructions.

Your dealer will be glad to assist you with any questions.

CE Declaration of conformity

In accordance with EG Directives 98/37/EC, 2000/14/EC and 89/336/EEC (amended by 92/31/EEC), SOLO Kleinmotoren GmbH, Stuttgarter Strasse 41, D-71069 Sindelfingen, being solely responsible, states that the product referred to in this declaration complies with the requirements of the Machinery Directive.

106

Sound power level (DIN45635)

Guaranteed sound	110 dB(A)
Actual sound	105 dB(A)

Applied standards:	EN 11806
Conformity assessment procedures	Appendix V

This declaration of conformity loses its validity, if the equipment is converted or modified without the manufacturer's consent.

Sindelfingen,
1- January 2005
SOLO Kleinmotoren GmbH

Wolfgang Emmerich
Executive Director

The following symbols are used in this manual and on the product:



Thoroughly read these operating instructions before undertaking any maintenance, installation and cleaning steps



Wear ear defenders and a face shield before starting the engine



Wear protective gloves when handling and working with the equipment



Wear solid shoes, preferably safety shoes with a good tread



Always handle this power tool with particular care



Maintain a minimum distance of 15 metres bystanders



Please note: objects may be thrown out and high



Never smoke near the power tool or where the equipment is refuelled!



Keep open flames away from the power tool and the fuel can



- This equipment produces exhaust fumes and
- fuel vapours are poisonous;
never start or refuel in enclosed spaces



Never use serrated cutters; generally use only cutters approved for the equipment type

Packaging

The packing materials used to protect the unit against damage during transportation are cartons made from pulp, which can be re-used or recycled.

	Page
1. Safety regulations	4
1.1 General safety instructions	4
1.2 Working clothes	4
1.3 Fuelling	5
1.4 When transporting the equipment	5
1.5 Maintenance and repairs	5
1.6 Preparing the equipment for starting	5
1.7 Starting	5
1.8 Working with the machine	6
2. Specification	7
3. Standard delivery	8
4. Control and function elements	8
5. Preparing the equipment for use	9
5.1 Installation - Loop handle Model 106L	9
5.2 Installation - Bicycle handlebar Model 106B	9
5.3 Shield installation	10
5.4 Cutter installation	10
5.5 Shoulder strap adjustment	11
6. Fuelling	12
6.1 Fuel information	12
6.2 Mixing ratio	12
6.3 Fuelling	12
7. Starting / Stopping the engine	12
7.1 Half throttle start position	12
7.2 Choke and primer	12
7.3 Starting	13
7.4 Engine will not start:	13
7.5 Turning off the engine:	13
8. Using your brushcutter	14
8.1 Scope of Application	14
8.2 Correct brushcutter operation	14
8.3 Adjusting the cutting line	14
9. Operating and maintenance instructions	15
9.1 General operating and maintenance instructions	15
9.2 The starter	15
9.3 Gearbox lubrication	15
9.4 Information about the spark plug	16
9.5 Carburettor adjustment	16
9.6 Information about the silencer	16
9.7 Air Filter Maintenance	17
9.8 Replacing the fuel filter	17
9.9 Shutdown and storage	17
9.10 Scheduled maintenance	18
10. Accessories / spare parts	19
11. Parts subject to wear and tear	19
12. Guarantee	19

1. Safety regulations

1.1 General safety instructions



Read the operating instructions carefully before taking this equipment into service and keep them in a safe place. Use this power tool with particular caution.

Non-observance of safety instructions can lead to a risk to life. Also observe any regulations from your professional body. These operating instructions must always be available at the place of work. All individuals instructed to work with the equipment (including maintenance, care and repair), should read these instructions.

- You should request and receive instructions from the vendor on the safe operation if you are using this type of product for the first time.
- This machine may only be used within the prescribed scope of application as stated in section 8.1 "Scope of Application".
- Children and young people under 18 years may not work with this power tool, with the exception of young people over 16 years of age who are being trained under supervision.
- Keep bystanders and animals away from the working area. Maintain a minimum distance of 15 m. When working near thickets, be aware that children and animals may be hidden there. Immediately stop the machine and the cutter if any person or animal comes close to the working area. The operator is responsible for any accidents or damage caused to parties or property.
- This machine may only be passed on or lent to third parties if they are familiar with the safe use of this product and with these instructions. Always supply the manual with the machine.
- Ensure you are rested and in good health when using this machine.
- Persons under the influence of alcohol or drugs, including prescription drugs, are not allowed to use this machine, as their ability to quickly react to potential danger may be impaired.
- Never alter, change or modify any safety equipment or functional assemblies on this machine.
- Only use this machine if it is in good, safe condition. Always check the machine prior to use. **Risk of accident!**
- Only use those accessories and attachments that have been supplied by the manufacturer and that are expressly approved for attachment. When using a nylon head, never replace a plastic line with a steel line. Always use the appropriate contact protection with each cutter.
- Always stop the engine and remove the spark plug cap when changing cutters to prevent unintentional starting of the engine.
- The reliability and safe operation of your machine depend on the quality of parts used with the machine. Only use original spare parts. Original spare parts are identical with genuine production parts and guarantee best quality in material, dimensions, function and safety. Original parts and accessories are available from your specialist dealer. Your dealer has been supplied with appropriate documentation to determine the correct parts. Your dealer is frequently supplied with updates about improvements to the equipment. Please note that the use of non-original parts will void your warranty.
- Always store the machine in a safe place and in such a way that it will not pose any danger. Stop the engine when the machine is not used.

Persons who disregard safety instructions, operating or maintenance instructions may be liable for any damage or consequential losses.

1.2 Working clothes

To prevent injuries, always wear suitable clothing and safety equipment when working with this power tool. This clothing should be practically oriented to the application (for example a tight fitting work suit), but should not be confining.

We recommend: **SOLO forest and countryside work jacket EN 340** Part no: 99 303 000 + size (2[s] - 6[xxl])
SOLO Outdoor Knee-breeches Part no: 99 020 95 + size
 or **SOLO Outdoor dungarees** Part no: 99 020 94 + size

Never wear scarves, ties, jewellery or other items of clothing, which might get caught in the equipment, in brush or on branches. Safely tie back long hair (use a cap, helmet or similar).



Wear sturdy shoes with a good tread - ideally safety shoes.

We recommend: **SOLO leather forest boots** Part no: 99 305 00 + size (36 - 48)



Wear protective gloves with non-slip palms.



Use ear defenders and/or a visor for protection against flying objects or objects caught up in the turbulence (protective goggles for example).

We recommend: **SOLO face/ear protection pack** Part no: 99 390 1001 (one size)

1.3 Fuelling



Petrol is very light and highly flammable. Keep away from open flames and never spill fuel. Do not smoke at the operating site or at and near the refuelling site!

- Stop the engine prior to refuelling.
- Let the engine cool down before refuelling - fire risk!
- Open the tank lid slowly to allow any excess pressure in the tank to be reduced without the risk of petrol spraying out.
- Fuel may contain substances similar to solvents. Prevent products made from mineral oil coming into contact with skin and eyes. Wear protective gloves during filling with fuel. Frequently change and clean protective clothing.
- Avoid breathing in fuel vapour.
- The refuelling site should be well ventilated.
- Avoid any soil spillage of fuel or oil (protection of the environment). Use a suitable mat.
- Immediately clean any spilled fuel on the machine. Change contaminated clothing without delay.
- Firmly tighten all tank lids. This will reduce the risk of spillage from lids, which have become loose from engine vibrations.
- Check for petrol leaks. Do not start the machine or work with the machine if there is a petrol leak. Life threatening risk from burns!
- Store fuel and oil in approved and correctly labelled containers.

1.4 When transporting the equipment

- Always turn off the engine when transporting the machine.
- Never carry or transport the brushcutter with the engine running.
- Always cover the cutters with blade protectors, when transporting the equipment over longer distances.
- To prevent fuel running out and associated damages, secure the equipment against tipping over during vehicle transportation. Check the tank for leaks. It is advisable to drain the tank before transportation.
- Drain the tank before despatching the equipment.

1.5 Maintenance and repairs

Regularly service this machine. Only carry out those maintenance jobs and repairs, which are described in this manual. A specialised service centre will carry out all other jobs.

- Do not maintain, repair or store the machine near an open flame.
- Before cleaning, maintenance and repair work, always stop the engine first and pull the spark plug cap. Exceptions: carburettor and idle adjustments.
- For any repairs only use original parts from the manufacturer.
- Do not modify, alter or change the machine as this may impact on the safe operation of the machine and may lead to accidents and injuries!

1.6 Preparing the equipment for starting

Check the complete machine for operational safety.



- The stop switch should function properly.
- The throttle must have freedom of movement and return to the idle position on its own accord.
- The cutters and contact protection must be tightly secured and in perfect condition.
- Ensure the spark plug cap and the ignition cable are connected firmly. A loose connection may cause a spark, which can ignite any existing fuel:air mixture - fire hazard!

Should the check reveal any irregularities or recognisable damage (also to the frame), incorrect adjustments or reduced efficiency of the machine, do not commence work. Take the power tool to a specialised workshop and have it checked.

1.7 Starting

- Start the machine no less than 3 metres from the refuelling location. Never start the machine in an enclosed space.
- Ensure that you are standing firmly on the ground when starting. Always start on even ground, with a firm grip on the power tool.
- Only one person at the time may operate this power tool - no other people should be within a radius of 15 m - even when starting.
- Continue with the starting procedure as described in section 7. "Starting/Stopping the engine".

1.8 Working with the machine

- Only use this power tool when it is complete and in a safe condition.
-  As soon as the engine is running, the power tool generates toxic gases, which may be invisible and odourless. Never work with the power tool in enclosed spaces. In confined conditions such as pits or excavations, ensure adequate air changes during work.
-  Do not smoke at the work site and in the immediate vicinity of the power tool. There is an increased fire hazard!
- Work conscientiously, thoughtfully and calmly, and do not endanger third parties.
 - Pay attention to good visibility and lighting conditions.
 - Always remain within earshot of other people who can provide help in case of emergency.
 - Plan for timely work breaks.
 - Pay attention to possible hazards and take appropriate precautions. Be aware that wearing ear defenders reduces the ability to perceive noise. This includes sounds alerting to danger such as signals, shouts, etc. that can go unnoticed.
 - Exercise caution when the ground is wet or covered in ice and snow, on overhangs, or uneven terrain. There is an increased risk of slipping!
 - Pay attention to the risk of stumbling and obstacles, such as tree roots and stumps, edges, etc. Pay particular attention to safety when working on slopes.
 - Before commencing work, check the working area for stones, broken glass, nails, wire or other solid objects and remove such debris to prevent them being picked up and thrown out by the cutters.
 - Always hold this power tool firmly in both hands, and ensure your safe and solid foothold.
 - Always hold the cutters below hip level. Never lift a rotating cutter off the ground.
 - Keep all parts of the body away from rotating cutters.
 - Use a correct operating mode (see Chapter 8.2 "Correct brushcutter operation").
 - Use the power tool at lowest possible noise and exhaust levels. Only open the throttle when working, do not let the engine run unnecessarily. Please note that noise also impacts on the environment. Observe the quiet times that can vary from place to place.
 - Never use blunt cutters and avoid uncontrolled contact of the cutter with debris. Otherwise there will be an increased risk of the equipment kicking, which could throw the entire machine around. As a result, the operator could be subjected to involuntary movements, which could lead to serious injury or death.
- Stop the engine if you notice a difference in the operating characteristics of the brushcutter.
- Due to the centrifugal clutch, the cutters will run on for a short time, even if you release the throttle. Ensure the cutter has come to a full stop before storing the machine.
- Always stop the engine before any contact with the cutter – even when clearing a blockage or if cutters have become jammed – wait until the cutter has stopped and remove the spark plug cap.
- Never touch the exhaust or the silencer; as long as they are still hot, there is a risk of burns!
- Never work with a defective or missing silencer. There is a hazard of hearing damage and burning!

First Aid

A first aid box should always be available on-site. Immediately replace any materials you have used:

Note:

Over exposing persons with circulatory problems to vibrations can lead to damage to their nervous system or blood vessels. The following systems may occur from vibrations to fingers, hands or the wrists: Numbness, itching, pain, twinges, changes to the colour of the skin or the skin itself. Seek medical advice if you experience any of these symptoms.

2. Specification

Brushcutter	106L	106B
Engine type	SOLO single cylinder two-stroke engine	
Engine capacity cm³	25	
Engine power kW at rpm	0,7 / 7500	
Max. permissible speed no load with cutter rpm	9000	
Medium idling speed rpm	2900	
Fuel tank capacity l	0,4	
Fuel mix ratio: with SOLO 2T engine oil with other two-stroke oils	1:50 (2%) 1:25 (4%)	
Fuel consumption at max. power (ISO 7293) kg/h	0,480	
Specific consumption at max. power (ISO 7293) g/kWh	600	
Carburettor	All-position diaphragm carburettor with primer and integrated fuel pump	
Air filter	Foam filter	
Ignition	Electronically controlled magneto ignition, maintenance free	
Gear reduction	1,25 : 1	
Drive shaft – property / diameter mm	Flexible / 6,2	
Shaft tube – material / diameter Ø mm	Aluminium / 25	
<ul style="list-style-type: none"> • Cutter: (subject to model) <ul style="list-style-type: none"> ▪ Grass cutter blade or Ø mm ▪ Nylon head Ø mm 	230 max. 360	
Weighted effective acceleration (ISO 7916) Handle r.h. side / handle l.h. side m/s²	3,9 / 4,4	4,8 / 3,8
Sound power level $L_{W_{eq}}$ to EN ISO 3744 actual / guaranteed 95% dB(A)	105 / 110	
Dimensions mm Height / Width / Length	26 / 33 / 178	46 / 67 / 180
Weight, w/o shield and cutter kg	4,6	5,0

3. Standard delivery

- **Brushcutter** partially assembled; the following components are supplied separately and require assembly
- **Handle** subject to model and all parts required to complete the assembly
- **Shoulder strap** (only model 106B)
- **Shield**, protective bar, line trimmer with screw and all parts required to assemble the shield
- **Cutter**: (subject to model)
 - Grass cutter blade **or**
 - Nylon head
- All **assembly parts** required to fit the grass cutter blade and the nylon head (all models)
- **Retaining pin (allen wrench)**(for fitting the cutter)
- **Instruction manual**

4. Control and function elements

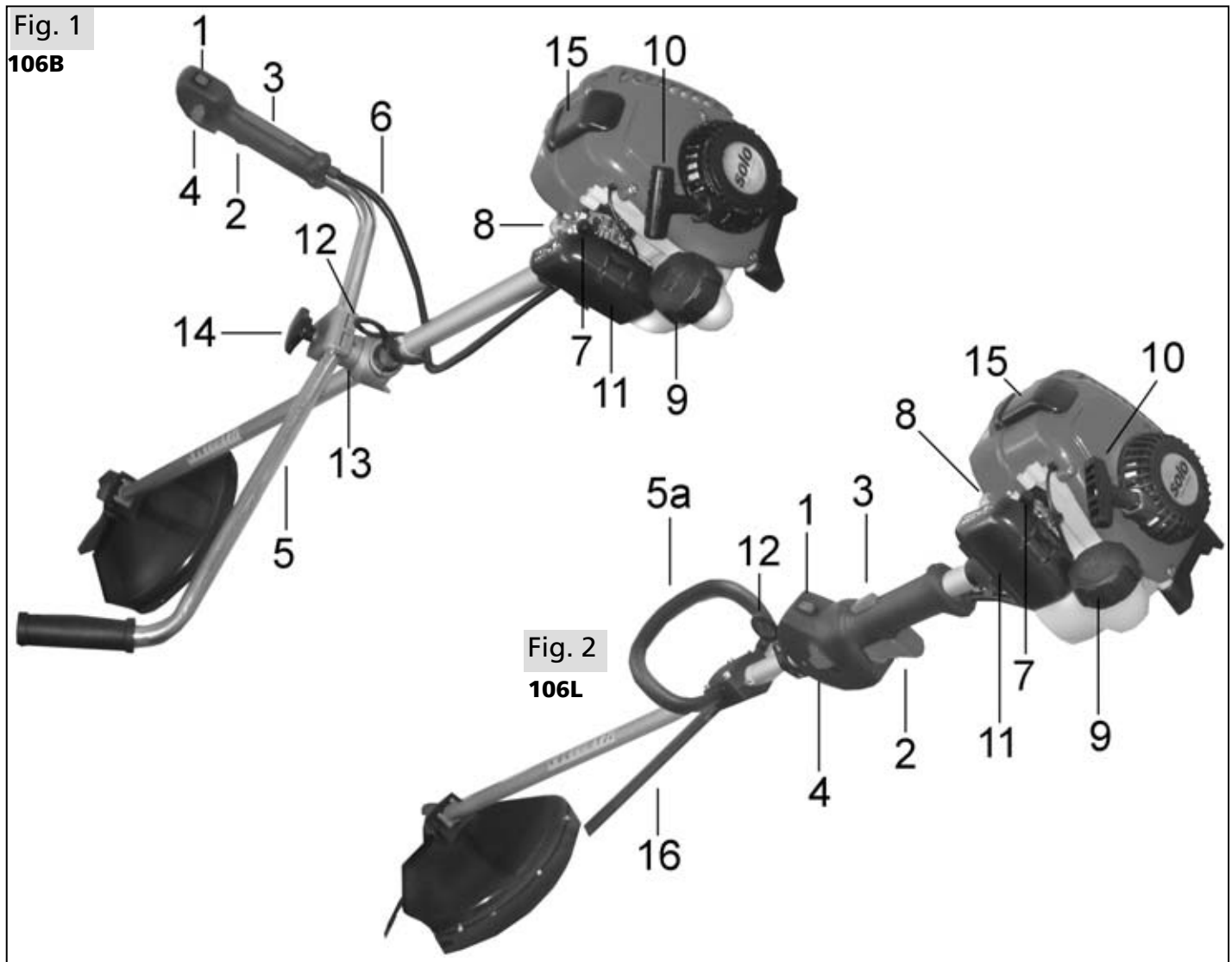

- | | | |
|--|---|-------------------------------------|
| 1 Stop-switch | 5a Loop handle (only model 106L) | 11 Air filter cover |
| 2 Throttle lever | 6 Throttle Bowden cable | 12 Harness rail |
| 3 Throttle lock | 7 Choke lever | 13 Handle support (only model 106B) |
| 4 Half throttle lock | 8 Primer | 14 Central screw (only model 106B) |
| 5 Bicycle handlebar (only model 106B) | 9 Fuel cap | 15 Sparkplug cap |
| | 10 Starter grip | 16 Safety stop (only model 106L) |

5. Preparing the equipment for use

For shipping purposes, the brushcutter is partly disassembled and has to be reassembled prior to use.

Only use the brushcutter after it has been fully assembled.

Ensure that the tank is fully drained before any assembly, disassembly or modification.

5.1 Installation - **Loop handle** Model 106L

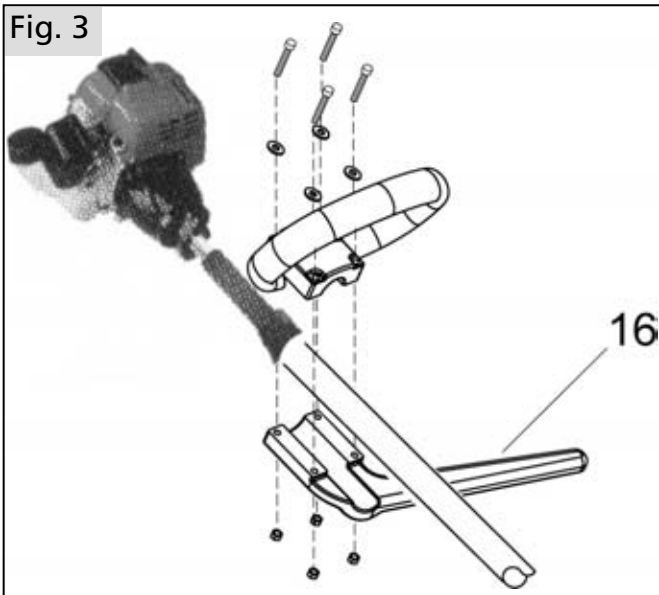

- Install the safety stop (16) pointing to the left (viewed from the operator position).
- Initially tighten the screws only lightly.
- Push the handle, in accordance with your body size, into its optimum position.
- Then tighten the screws.

5.2 Installation - **Bicycle handlebar** Model 106B

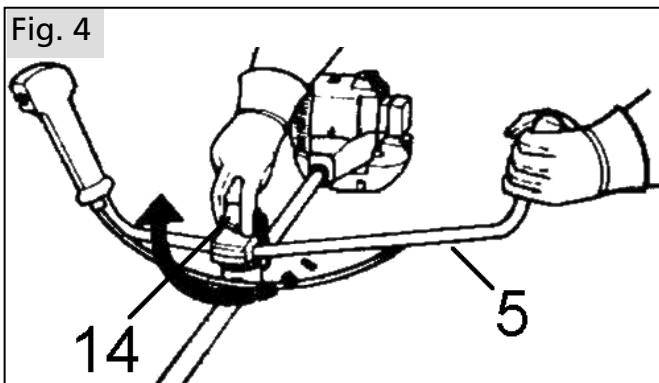

With the central screw (14) released, turn the two-hand **bike** handle (5) into the correct position and tighten the central screw.

The r.h. side of handle (5) should be fitted as near as possible to the handle support.

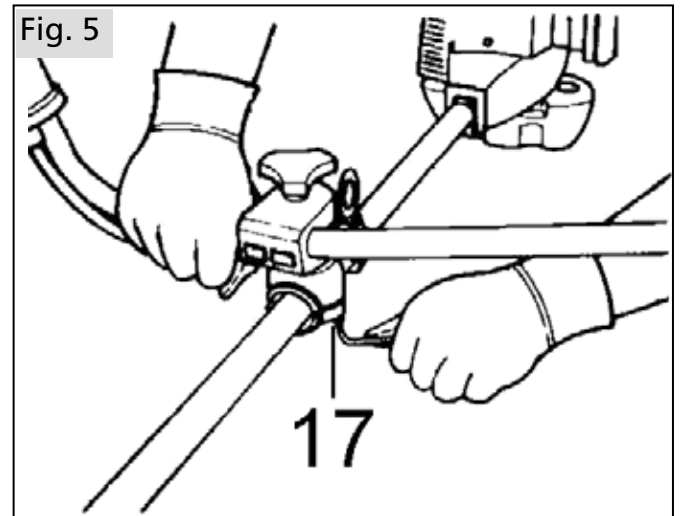

Release both screws (17) to move the handle support. Push the entire handle assembly on the shaft tube into the position, which suits the size of operator, and tighten both screws again.

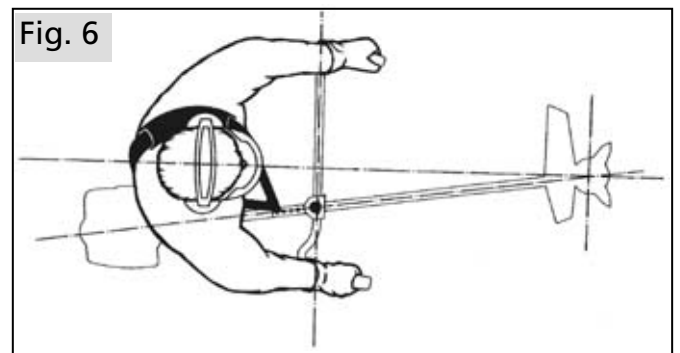

You will have achieved an optimum adjustment, if the centre of the power tool is at the centre of your body. Your elbow should be slightly angled in operating position.

Important: Always lead the brushcutter on the r.h. side of the body!

5.3 Shield installation

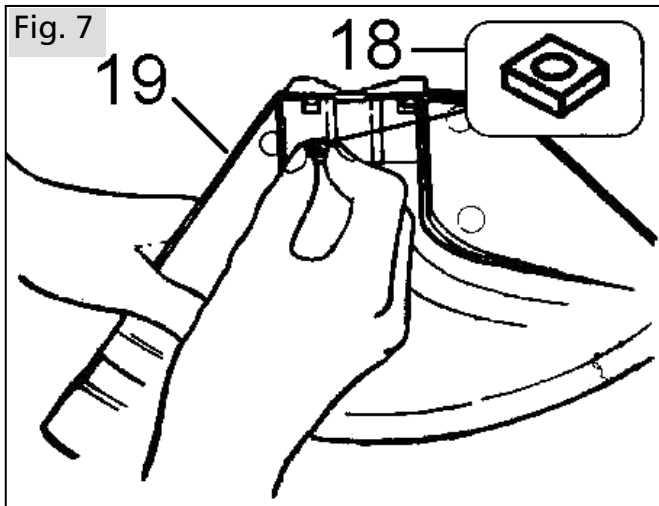

Insert both square nuts (18) from below into the contact protector (19).

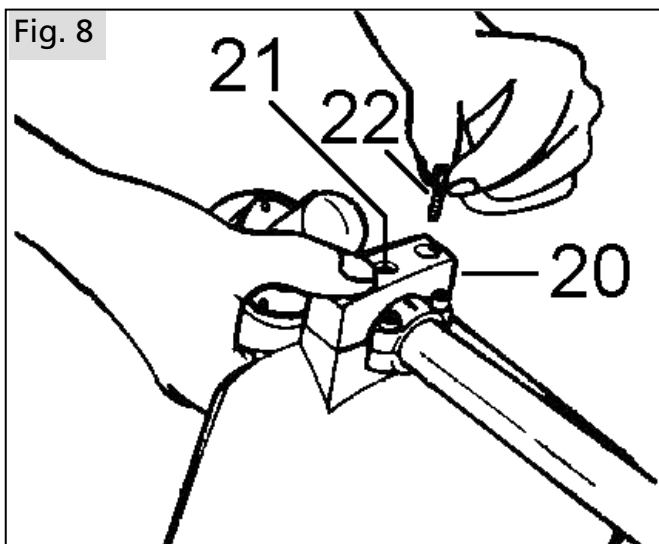

Locate the fixing part (20) on the gearbox so, that the gearbox screw locates in the central hole (21). Secure the contact protector with both screws (22) in the outer holes of the fixing part.

5.4 Cutter installation

Always switch off the engine, pull the spark plug cap and wear protective gloves when fitting or replacing the cutter!

Subject to model, the brushcutter will be supplied either with a grass cutter blade or with a nylon head.

A) Fitting the nylon head

(subject to model)

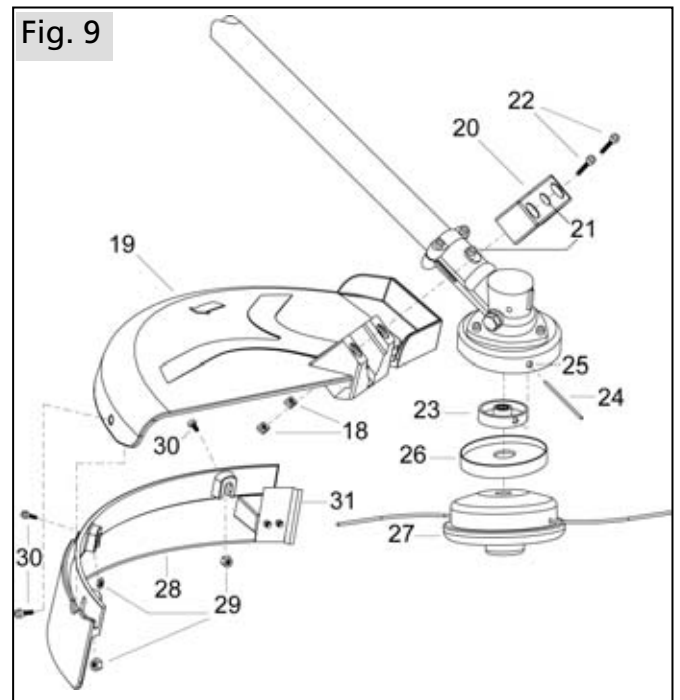

- Position thrust piece (23) on gear shaf.
- Rotate the gear shaft with the thrust piece, so that the recess for retaining pin (allen wrench)(24) is flush with the recess in winding protection (25) or the gearbox casing.
- Insert the retaining pin to lock the gearbox.
- Rotate the complete nylon head (27) with the additional line winding protection (26) on the gear shaft against the thrust piece. Please note: Left-hand thread! Tighten anti-clockwise against the nylon head.
- Push the protective bar (28) from below onto the shield. For this, insert the hexagon nuts (29) into the protective bar, then fit the protective bar with the three screws (30).

Please Note: When operating with the nylon head, never start the engine without fitted protection bar and line trimming blade (31).

Note: When the nylon line length is adjusted (see chapt."8.3 Adjusting the nylon line"), the line trimmer blade (31) will trim the line automatically to the correct length.

B) Fitting the grass cutter blade

(subject to model)

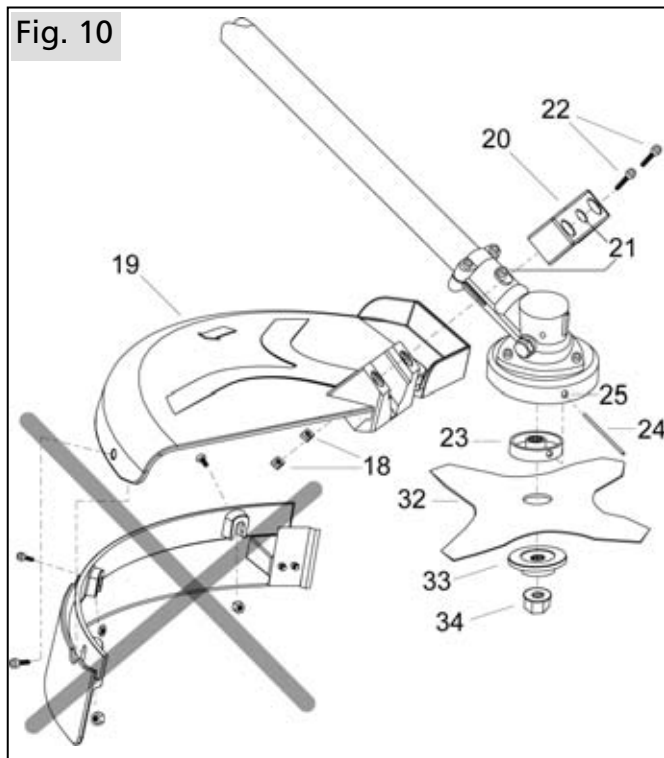
**Information regarding the guard bar (28):**

Always operate without the guard bar (28) when using the grass cutting blade.

- Position thrust piece (23) on gear shaft.
- Fit the grass cutting blade (32) snugly onto the drive shaft.
- Position disc (33), and lightly secure locking nut (34). Please note: left-hand thread! Fit the nut anti-clockwise.
- Lock the gear shaft; for this, insert assembly pin (allen wrench) (24) through the recess in winding guard (25).
- Slightly turn the gear shaft, until assembly pin (24) catches in the recess of thrust piece (23).
- Tighten nut (34) (25 Nm). Please note: Left-hand thread! Tighten the nut anti-clockwise.
- Remove assembly pin (24), and check the free rotation of the grass cutter blade.

5.5 Shoulder strap adjustment

(subject to model)

Before commencing work, adjust the shoulder strap and handle according to the operator's body size.

Position the single shoulder strap over your l.h. shoulder, so that, after adjusting the strap length, the strap hook is located at your r.h. hip.

Balance the brushcutter with fitted cutting tool so, that the cutter hovers just above the ground, without touching the suspended brushcutter with your hands.

If the cutting tool hovers more than 10 cm above the ground, secure the shoulder strap retainer nearer to the motor.

If the cutter lies on the ground, secure the shoulder strap retainer nearer the handle.

6. Fuelling

6.1 Fuel information

A high performance two-stroke engine operated with a petrol:oil mixture (petrol + oil = fuel mixture) or with a special fuel mixture for two-stroke engines available from specialists powers this machine. The fuel mixture can be made up with standard lead-free petrol or with lead-free premium grade petrol. The minimum octane rating for petrol is 92 ROZ.

Unsuitable petrol or deviations in the mixing ratio may lead to serious engine damage!



Avoid direct skin contact with petrol and avoid inhaling petrol fumes - health hazard!

6.2 Mixing ratio

Always use a fuel:oil ratio of 25:1 (4%) for the first five tank fillings.

After that we recommend a ratio of 50:1 (2%) with the use of special two-stroke oil "SOLO 2T engine oil" which we can supply.

With the use of other brand two-stroke oils we recommend a ratio of 25:1 (4%).

Never store fuel mixture longer than 3 - 4 weeks.

Fuel mixture table

Petrol in litres	Oil in litres	
	SOLO 2T engine oil 2% (50 : 1)	Other two-stroke oils 4% (25 : 1)
1	0,020	0,040
5	0,100	0,200
10	0,200	0,400

6.3 Fuelling

While fuelling always follow all safety instructions and take all safety precautions.

Handle fuel only with the engine turned off. Carefully clean the area around the filler inlet. Place the machine with the fuel inlet pointing upwards. Unscrew the tank lid and fill the fuel mixture up to the lower edge of the filler neck. Use a funnel with filter to prevent tank contamination. After filling the tank replace the tank lid and tighten firmly.

7. Starting / Stopping the engine

7.1 Half throttle start position

Fig. 11

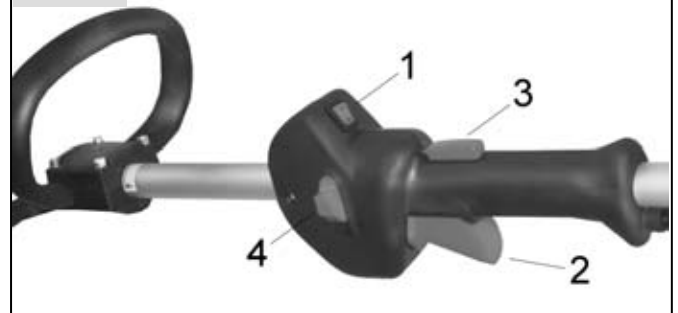

(Fig.: Model 106L)

- Move the stop switch (1) to "ON".
- Grip the handle; the safety locking key (3) is activated via the grip area, which also enables throttle lever (2) to be regulated.
- Press throttle lever (2) fully down.
- Press the half throttle lock (4), and let the throttle lever return, whilst holding the half throttle lock in.

7.2 Choke and primer

Fig. 12



Adjust choke (7) as follows:

- With a cold engine, position choke lever (7) up towards "Close" ↑.
- With a warm engine, position choke lever (7) down towards "Open" ↓.

When first starting or if the fuel tank has been completely drained and has been refilled, press primer (8) several times (at least 5x) until the fuel is visible in the plastic bulb.

7.3 Starting

Observe the safety instructions when starting.

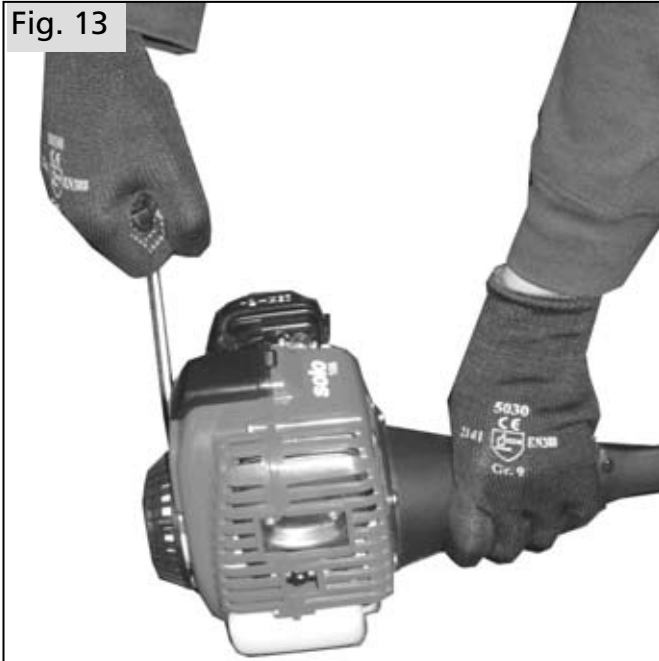

Place the brushcutter level and without obstructions on the ground.

During starting, never stand or kneel on the shaft tube, otherwise the shaft or the tube might be damaged.

Take up a safe position, securely hold the machine and ensure that the cutter does not touch any objects or the ground.

If the engine is cold:

With the choke lever up (↑), pull the starter cord several times in a straight line, until you can hear the engine firing.

Immediately afterwards, move the choke lever down (↓). Continue starting until the engine turns over.

If the engine is warm:

With the choke lever down (↓), start until the engine turns over.

Please note: Never pull the starter cord out at an angle and do not pull all the way out, otherwise there is a risk that the cord might break! Do not let the starter cord snatch back!

Once the engine runs, briefly pull the throttle back to release the half throttle detent. Release the throttle lever again to allow the engine to run at idle speed. Now you can commence working.

7.4 Engine will not start:

If the engine fails to start after several attempts, check whether all adjustments described above have been correctly carried out, particularly that the stop switch is **not** in the "OFF" position. Try starting once again. The combustion chamber will be flooded, if the engine still fails to start.

In that case we recommend you proceed as follows:

- Remove the spark plug cover.
- Pull the spark plug cap off the spark plug.
- Remove the spark plug and dry fuel mixture from the electrodes.
- Move the throttle lever up to full throttle. Pull the starter handle several times (with removed spark plug) to clear the combustion chamber.
- Move the throttle lever down to idling position, refit the spark plug, the plug cap and the plug cover.
- Start the engine with the choke lever down (↓) and the stop switch in the "ON" position.

7.5 Turning off the engine:

Release the throttle and push the stop switch to "OFF".

Important: Due to the centrifugal clutch, the cutter will run on for a short time, even if you release the throttle. Ensure the cutter has come to a full standstill before storing the machine.

8. Using your brushcutter

8.1 Scope of Application

Only use brushcutters equipped with a nylon head (subject to model) for cutting grass – particularly suitable around obstacles - and for trimming light weeds and wild growth near ground level. The nylon head is particularly suitable for a soft cut, e.g. for clean trimming around trees and posts.

Use brushcutters equipped with the grass cutter blade (subject to model) only for cutting grass away from obstacles and for cutting stronger weeds and wild growth near ground level.

As standard model, the brushcutter is unsuitable for any other purpose.

Generally, use only the cutting tools authorised for use with this brushcutter. Always fit the contact shield specified for this brushcutter and cutting tool. If in doubt, contact your local SOLO dealer.

8.2 Correct brushcutter operation

Observe the relevant safety instructions when using the brushcutter.

The rotational direction of the cutting tool makes the operation on the l.h. side of the cutting tool (from the operator's viewpoint, subject to the brushcutter being held correctly) particularly free from kicking. Therefore, always approach the area to be cut from the right. This brings the l.h. side of the cutting tool into contact with the material to be trimmed first. Particularly when cutting tougher growth (such as medium sized weeds and wild growth) with a grass cutter blade, ensure that you do not "stab" the front of the brushcutter into the material to be trimmed.

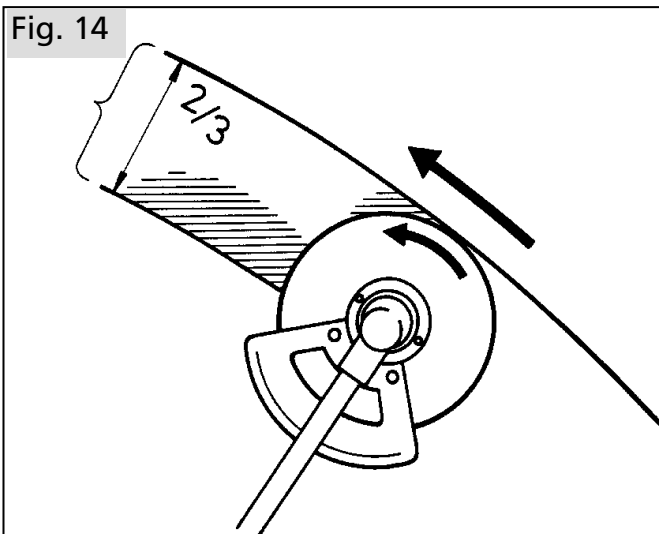

Approach the working area with the brushcutter set to idle, and then switch to full throttle. Never leave the engine running at high speed without applying a load.

Dip the tool from the r.h. side 2/3 into the material to be trimmed. Then work the brushcutter like a scythe, i.e. by moving forward step by step, whilst cutting from right to left.

Operate the brushcutter at full throttle to obtain an optimum cutting result. Never operate with the clutch in slipping range. Consequential damage through excess loads or overheating is excluded from our warranty.

Immediately stop the engine in case of noticeable vibrations or when material has gathered around the cutting tool or contact shield. Slow down the cutting tool by pressing it onto the ground, until it has come to a complete standstill. Pull the spark plug cap from the plug, and clean the tool seat of all grass, roots etc. Check the entire brushcutter for perfect condition.

When using the nylon head, always ensure that you operate only with the correct length of line. When the contact shield is fitted, the line will always be trimmed to the permissible length automatically (a line trimming blade is fitted into the shield). There is a high risk of injury, and the engine is subjected to excessive loads leading to a risk of damage, if nylon lines are left too long.

Therefore, when converting the cutting tool from grass cutter blade to nylon head, always fit the standard contact shield together with the protective bar and fitted line trimming blade (Fig. 9/31).

8.3 Adjusting the cutting line

When using a semi-automatic nylon head:

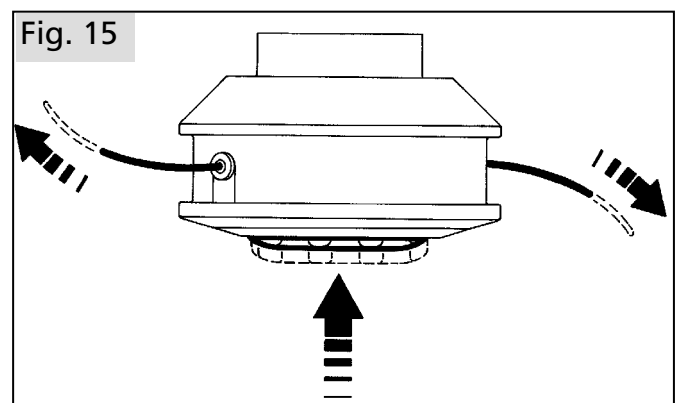

(schematic diagram)

Whilst the brushcutter is running without load, but with rotating nylon head, lightly push the nylon head several times onto ground with growth cover. The cutting line will be dispensed in stages. With each action, approx. 30 mm line will be dispensed. The line trimming blade will correct any excess length.

When the cutting line is fully spent, you can replace it with line available under part no. 6900942 (accessory).

9. Operating and maintenance instructions

9.1 General operating and maintenance instructions

The maintenance and the repair of modern machines as well as their safety-relevant assemblies require qualified specialised training and a workshop equipped with special tools and test equipment. Consequently the manufacturer recommends that all tasks not described in these operating instructions be carried out by a specialised workshop. That specialist has the required training, experience, and equipment at his disposal, to provide you with the most cost-effective solution for such work. He will provide additional help in word and deed.

After a running-in time of app. 5 hours, all accessible screws and nuts (except the carburettor adjusting screws) must be checked for tightness and they must be retightened, if required.

Check the cutter regularly and whenever you notice any irregularities, or when the cutter/contact shield becomes blocked. For this, switch off the engine and wait until the cutter has come to a complete standstill. Pull the spark plug cap, and remove grass, debris, etc. from the cutter support. Immediately replace blunt or damaged tools, even if they display only small cracks – do a "ping" test.

It is best to store the equipment in a dry, safe location with a full fuel tank. There should be no open flame or similar nearby. For longer periods without using the equipment (longer than four weeks), see chapter "9.9 Shutdown and storage".

9.2 The starter

The following instructions are aimed at increasing the service life of the starter rope and of the starter mechanism - see also chapter 7 "Starting / Stopping the engine":

- Always pull the rope out in a straight line.
- Do not let the rope drag across the edge of the rope eyelet.
- Do not pull rope all the way out - risk of the rope breaking.
- Always manually guide the rope back into its start position with your hand on the starter grip - do not let it retract on its own.

A specialist can replace a damaged starter rope.

9.3 Gearbox lubrication

To lubricate the bevel gear drive, use SOLO "Special gearbox grease" (part no. 0083180). Check the grease level weekly and top up, if required (approx. every 20 - 50 hours).

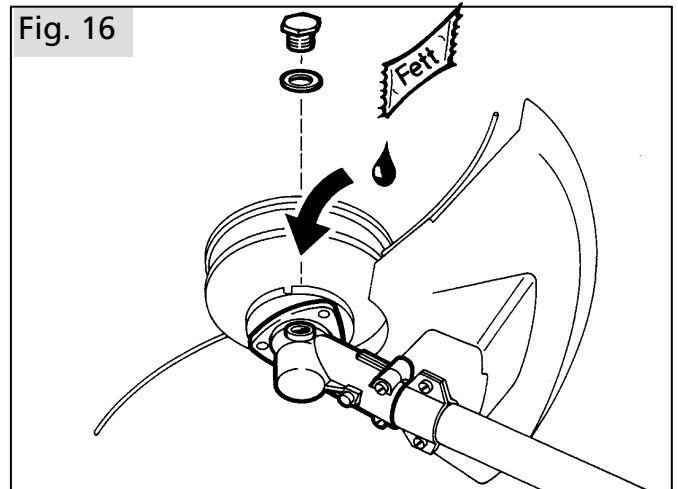

Remove the filler plug from the side of the gearbox. If no grease is visible inside, top up with grease (top-up quantity approx. 5 – 10 g). Replace and tighten the filler plug.

Please note: Do not overfill with grease, as that may lead to the gearbox overheating. Never fill the gearbox casing to the top with grease.

Tip: If required, top up with a maximum of 5g grease. It is preferable to check more frequently (e.g. before you start working) whether grease is still visible.

Your SOLO dealer workshop is happy to help you in case of doubt.

9.4 Information about the spark plug

Check the spark plug regularly after 50 hours of operation.

- Remove the spark plug cover.
- Disconnect the spark plug cap.
- Unscrew the spark plug and dry the electrodes.

The spark plug should be replaced after 100 hours of operation or if the electrodes are badly worn.

Do not turn the engine over while the spark plug has been removed or the spark plug cap has been disconnected from the high-tension ignition cable. A spark may cause a fire!

Spark plugs with resistor (thermal value 200) are available in different brands under the following description:

BOSCH WSR6F

CHAMPION RCJ-6Y or comparable.

The correct electrode gap is 0.5 mm.

Only use spark plugs, where the contact nut has been firmly fitted. Loose connectors may produce sparks, which can cause a fire.

- Insert the spark plug into the cylinder head and tighten it.
- Push the spark plug cap firmly over the spark plug.
- Refit the spark plug cover.

Before restarting the engine, check the high-tension ignition cable for any damage to its insulation and ensure the cable is connected securely to the plug cap.

9.5 Carburettor adjustment

The carburettor has been adjusted optimally at the factory. Subject to the operational altitude (mountains or low lying areas), the carburettor may require readjustment.

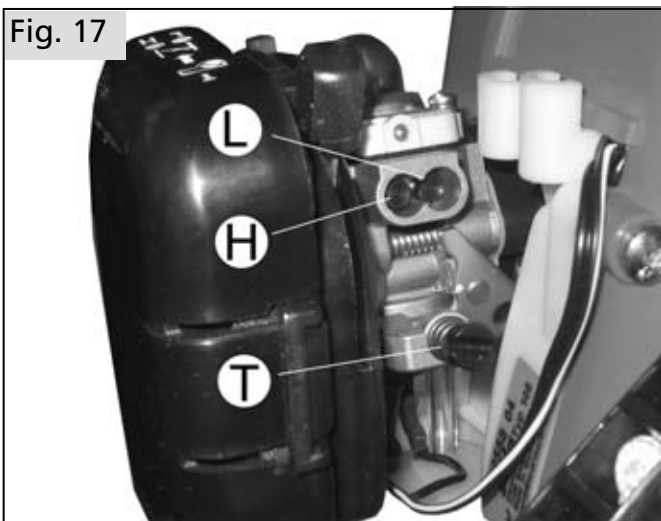

The carburettor has 3 adjusting screws:

- Idling end-stop screw "T"
- Low speed mixture screw "L"
- High speed mixture screw "H"

 Only qualified mechanics must adjust the regulating screws for idle mixture "L" and full load mixture "H".

Turn the idling end-stop screw "T" to adjust the idling speed in accordance with the details provided in the specification. Use an engine rev counter for this job.

- If the idling speed is too high, turn the idling end-stop screw "T" anti-clockwise.
- If the idling speed is too low (engine stops) turn the idling end-stop screw "T" clockwise until the engine runs smoothly.

 With the throttle set to idle, the cutting tool must not, under any circumstances, rotate!

If the idling speed cannot be set correctly with the idling end-stop screw "T", request an authorised service centre to tune the carburettor.

The following instructions are for authorised service shops

D-CUT carburettors:

Use the D-CUT carburettor key to adjust the idle mixture screw "L" and the full load mixture screw "H".

Carburettors with limiter caps:

The regulating screws for idle mixture and full load mixture can only be adjusted in a limited range.

Clean the air filter before adjusting the low speed screw!

Let the engine run warm before adjusting the engine speed.

 The carburettor is tuned for optimum engine performance. Use a rev counter to tune the carburettor correctly!
Do not adjust the engine to a higher speed. Excessive engine speed can lead to major engine damage!

9.6 Information about the silencer

Ensure the silencer is in perfect condition before operating the machine. Never touch the silencer while it is still hot.

Unsatisfactory engine performance, despite a clean air filter and a correctly adjusted carburettor, may well be due to a partially blocked or damaged silencer. Please consult your specialist service centre.

9.7 Air Filter Maintenance

Dirty air filters cause a reduction in engine performance and increase fuel consumption with more pollutants in the exhaust gas. Engines are less likely to start readily with a dirty and soiled air filter.

The following maintenance jobs should be carried out frequently.



Before opening the air filter, close the choke  to prevent dirt entering the carburettor. Press clip (35), tilt and remove the filter cover (11). Clean around the filter.

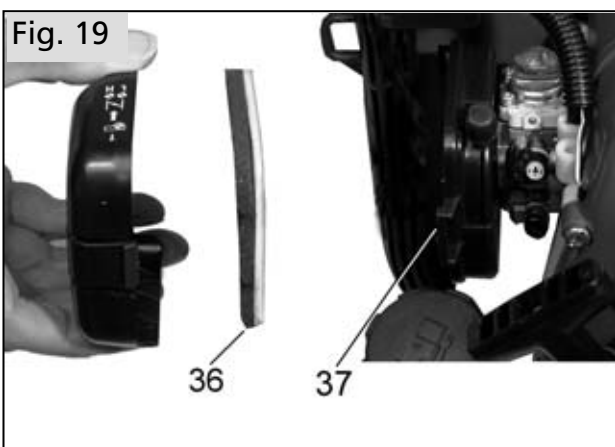

Remove the assembled filter element (36) from the filter retainer (37). **Please note: Never separate the filter element**

Please note: Never separate the filter element. Clean the filter more often in extreme dust conditions. For daily cleaning jobs simply tap the filters against a hard object or use compressed air. Damaged air filters should be replaced immediately. Warranty does not apply to engine damage caused by the lack of or improper maintenance.

Insert the new or cleaned filter element in accordance with Fig. 19 into the filter retainer. Then close the filter cover and secure it by clicking it into position.

Never insert moist or wet filter elements!

9.8 Replacing the fuel filter

We recommend having the fuel filter (40) changed annually by a specialised service centre.

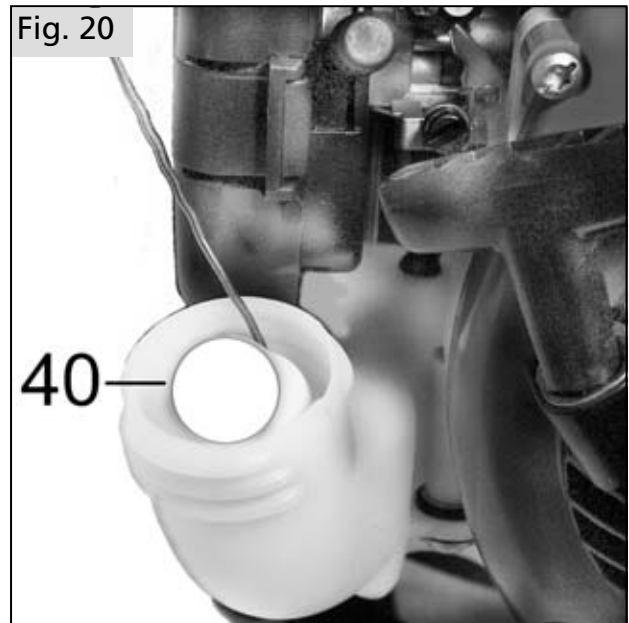

A trained mechanic can carefully remove the fuel filter via a wire loop through the fuel tank filler. Ensure that the thicker part of the fuel hose on the tank wall is not drawn into the fuel tank.

9.9 Shutdown and storage

Preferably, store the equipment in a dry and secure place with a full fuel tank. Open flames or similar must not be nearby. Prevent unauthorised use – particularly by children.

For stops longer than four weeks the following steps should be carried out:

- Empty and clean the fuel tank at a well-ventilated location.
- Start the engine with an empty fuel tank. Run the engine until the carburettor is empty and the engine stalls. Otherwise the carburettor nozzles could become encrusted with residual fuel mixture and make a subsequent start harder.
- Clean the power tool well (particularly the air intake openings, the cylinder fins, the air filter and the fuel filler area).
- Preferably, store the equipment in a dry and secure place with a full fuel tank. Open flames or similar must not be nearby. Prevent unauthorised access – particularly by children.

9.10 Scheduled maintenance

The following information is based on standard operating conditions. For special conditions, such as prolonged daily use, the recommended maintenance intervals should be reduced accordingly.

		after the first 5 hours	before starting work	weekly	after every 50 hours	after every 100 hours	as required	before the start of the mowing season, or once per year
Carburettor	Check idling speed		X					
	Adjust idling speed						X	
Air filter	Clean		X					
	Replace						X	
Spark plug	Check the electrode gap and adjust, if required				X			X
	Replace					X	X	
Gearbox lubricant	Check			X				X
	Top up				X		X	X
Grass cutter blade (subject to model and as accessory)	Check		X					
	Sharpen						X	
	Replace						X	
Cooling air inlet	Clean			X			X	X
Cylinder fins	Clean						X	X
Fuel tank	Clean				X			X
Fuel filter	Replace							X
All accessible screws (except for adjusting screws)	Retighten	X					X	X
Controls (stop switch, throttle lever, half throttle detent, starter)	Check function		X					
Silencer	Visual inspection		X					
Complete machine	Visual inspection		X					
	Clean			X			X	X

Implement all maintenance jobs regularly. If required, authorise a specialist service centre to maintain the machine for you. The owner of the machine is responsible for:

- Any damage caused by a lack of maintenance, incorrect or late maintenance and repairs
- Consequential losses - including corrosion - from incorrect storage

10. Accessories / spare parts

Accessories	Part no.
2 nylon head semi-automatic M10 x 1,25 left	69 00 651
Replacement line for nylon head 15 m, 2,4 mm	69 00 942
Grass cutter blade 4 teeth, Ø230 mm	69 00 948
Shoulder strap	69 00 924
High performance gearbox grease	00 83 180
SOLO 2T engine oil 100 ml	00 83 103
SOLO 2T engine oil 1 l	00 83 104
SOLO 2T engine oil In a metering bottle 1 l	00 83 105
SOLO face/ear protection pack	99 390 1001
SOLO forest and countryside work jacket EN 340	99 303 000 + size (2[s] - 6[xxl])
SOLO Outdoor Knee-breeches	99 020 95 + size
SOLO Outdoor dungarees	99 020 94 + size
SOLO leather forest boots	99 305 00 + size (36 - 48)

11. Parts subject to wear and tear

Various parts are subject to application-specific or normal wear and must be replaced in good time, when required. The following parts are subject to normal wear and are not covered by the manufacturer's guarantee:

- Air filter
- Fuel filter
- All rubber parts which come into contact with fuel
- Clutch
- Spark plug
- Starter
- Cutting tools

12. Guarantee

The manufacturer guarantees trouble-free quality and will cover the cost of replacing parts which are found to be faulty in material or workmanship within the prescribed guarantee period after the date of purchase. Please note that specific guarantee conditions may vary from country to country. If in doubt, ask your equipment vendor. He is responsible for guarantee matters.

We hope you will understand that we cannot be liable for damage resulting from the following causes:

- Non-compliance with the operating instructions.
- Neglecting essential maintenance and repair work.
- Damage caused by incorrect carburettor adjustment.
- Wear in normal use.
- Obvious overload by continuously exceeding the maximum performance limit of the product.
- Using non-authorized tools.
- Use of force, incorrect treatment, misuse and accidents.
- Damage from excessive heat due to dirt build-up around the cooling fan housing.
- Attempted adjustments and repairs by unqualified persons.
- Use of unsuitable spare parts or third party parts, if these are the cause of the defect.
- Use of unsuitable or stale fuel.
- Damage caused by using the product in the hire or rental industry.

Normal cleaning, adjustments or maintenance work fall outside the guarantee provisions.

A service centre authorised by the manufacturer must carry out all guarantee work.

In the best interest of continued technological progress we reserve the right to change the design and configuration of any product without prior notice.

For that reason, no claims can be accepted with reference to text and illustrations in this manual.

solo[®]

Made in Germany



SOLO
Postfach 60 01 52
D 71050 Sindelfingen

Tel. 07031-301-0
Fax 07031-130
info@solo-germany.com

SOLO
P.O.Box 60 01 52
D 71050 Sindelfingen
Germany
Phone+49-7031-301-0
Fax +49-7031-149
export@solo-germany.com